

Instruments for Removing DePuy Synthes Screws

Screw Removal Set

Surgical Technique

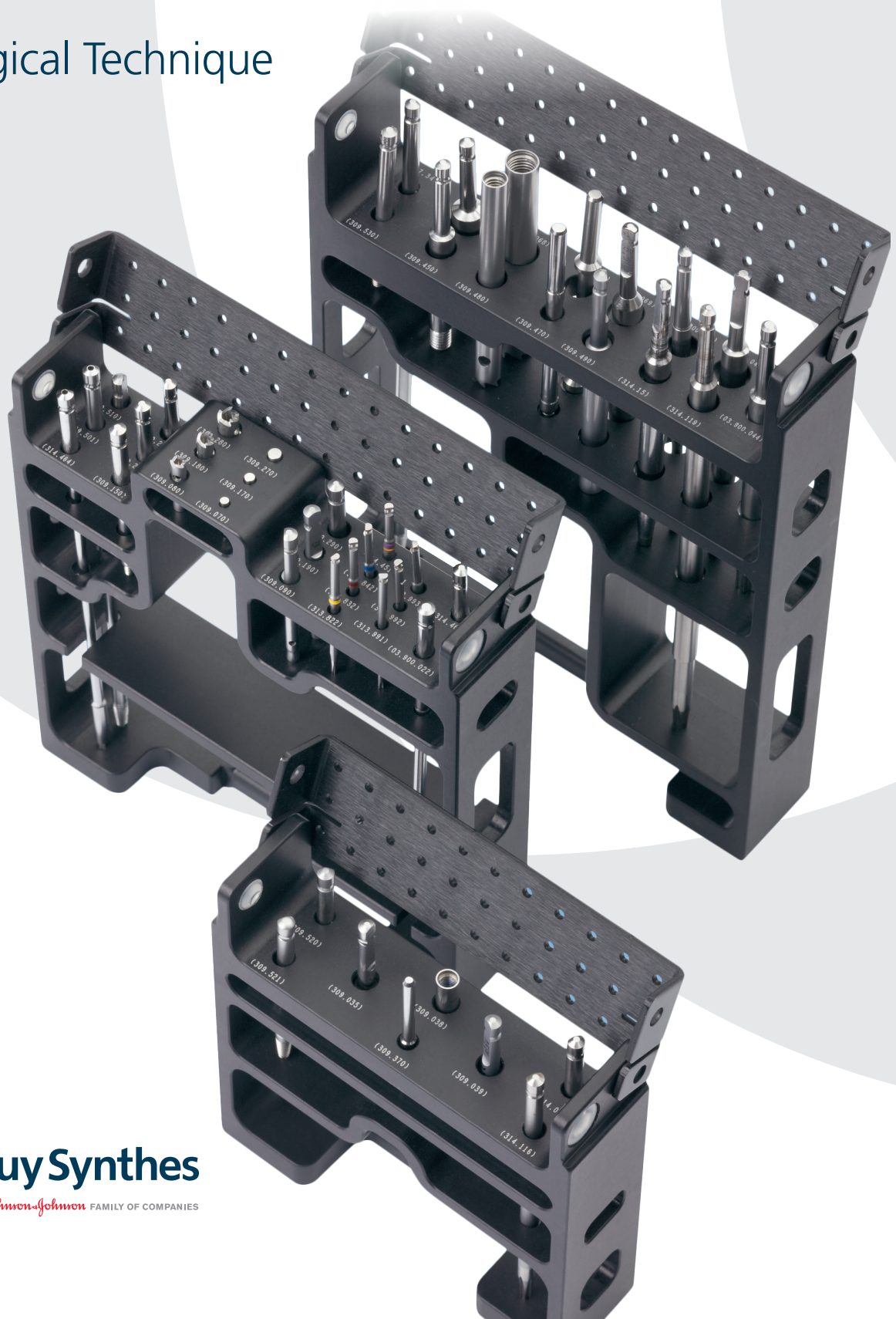

Table of Contents

Introduction	Screw Removal Set	2
---------------------	-------------------	---

Surgical Technique	Preoperative Planning and Preparation	6
	Removal of Intact Screws	7
	Removal of Broken Screws	9
	Removal of Screws with Damaged Recesses	13
	Removal of Jammed Screws	18

Product Information	Instruments	22
	Set List	28

MR Information

The Screw Removal Set has not been evaluated for safety and compatibility in the MR environment. It has not been tested for heating, migration or image artifact in the MR environment. The safety of the Screw Removal Set in the MR environment is unknown. Scanning a patient who has this device may result in patient injury.

Screw Removal Set. Instruments for removing DePuy Synthes screws.

The Screw Removal Set contains instruments required for removing intact screws or damaged screws that are difficult to remove.

Modular design

The modular design ensures that the assembly is ideally suited to requirements and the set is always complete. The clear layout makes the instruments easy to locate, thereby reducing the danger of selecting the wrong instrument.

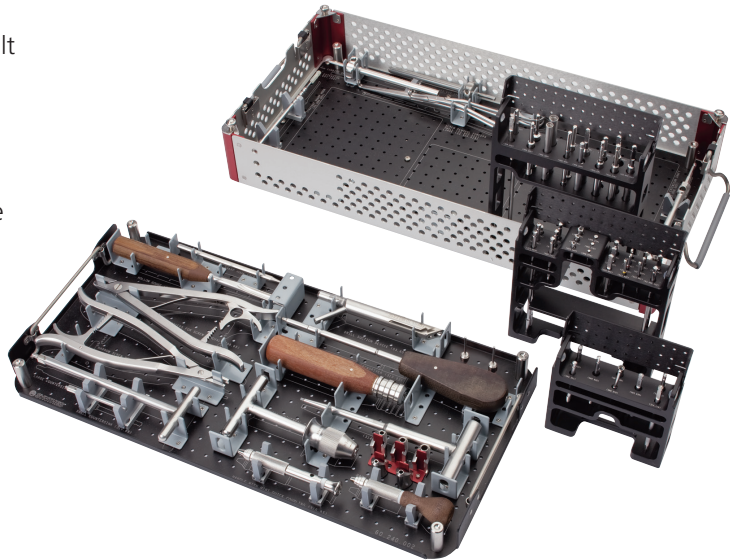

Comprehensive system

All existing DePuy Synthes screws can be removed with the instruments supplied in the Screw Removal Set. This prevents delays caused by missing or incorrect instruments.

The screw removal set contains screwdriver shafts for all DePuy Synthes screw sizes and drives, as well as extraction instruments for removing broken and damaged screws.

The set contains instruments to remove all screws with the following drive recesses:

- Hex: 1.5 mm, 2.5 mm, 3.5 mm, and 4.0 mm
- StarDrive™ Recess: T4, T5, T6, T8, T15, T25, and T40
- Cruciform: 1.0 mm, 1.3 mm, 1.5 mm, 2.0 mm, and 2.4 mm

The set contains instruments for removing the following screws:

- Cortex screws
- Cancellous bone screws
- Shaft screws
- Cannulated screws
- Locking screws
- Locking bolts

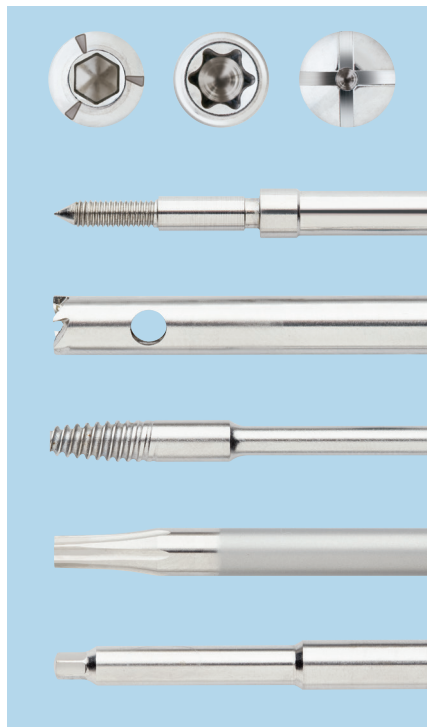

To remove intact screws

- Hex screwdriver shafts
- StarDrive Screwdriver shafts
- Cruciform screwdriver shafts

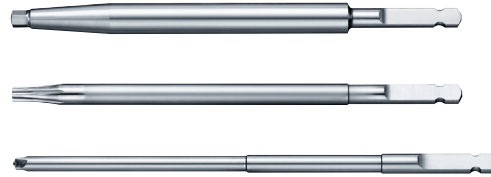

To remove broken screws

- Hollow reamer: use counterclockwise to expose deeply seated broken screw shafts
- Extraction bolts: use counterclockwise to remove exposed broken screw shafts

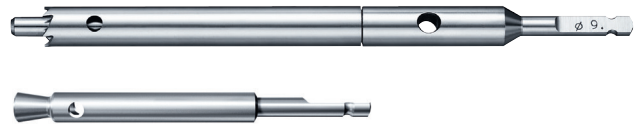

The following table shows which extraction instruments can be used to remove the various screw sizes. If several instruments can be used, select the one with the smallest external diameter.

Hollow reamer and extraction bolt for screw diameter (and drive recess)

		Screw diameter (and drive recess)																							
Recess																									
		1.0 mm/1.3 mm/1.5 mm (Cruciform)	1.5 mm (1.5 mm Hex)	2.0 mm (Cruciform)	2.0 mm (1.5 mm Hex)	2.0 mm (T6 StarDrive Recess)	2.4 mm (Cruciform)	2.4 mm (T8 StarDrive Recess)	2.7 mm (2.5 mm Hex)	2.7 mm (T8 StarDrive Recess)	2.7 mm (T15 StarDrive Recess)	3.5 mm (2.5 mm Hex)	3.5 mm (T15 StarDrive Recess)	3.9 mm (2.5 mm Hex)	3.9 mm (3.5 mm Hex)	4.0 mm (2.5 mm Hex)	4.0 mm (3.5 mm Hex)	4.0 mm (T25 StarDrive Recess)	4.5 mm (3.5 mm Hex)	4.9 mm (3.5 mm Hex)	5.0 mm (3.5 mm Hex)	5.0 mm (T25 StarDrive Recess)	6.0 mm (T25 StarDrive Recess)	6.5 mm (3.5 mm Hex)	
 Hollow reamers	309.150	•	•	•	•	•																			
	309.200			•	•	•																			
	309.250							•	•	•	•														
	309.035											•	•	•	•	•	•	•							
	309.450															•	•	•	•	•	•	•	•		
	309.065																							•	•
 Extraction bolts	309.090	•	•																						
	309.190			•	•	•																			
	309.290							•	•	•	•														
	309.039											•	•	•	•	•	•	•							
	309.490															•	•	•	•	•	•	•	•		
	309.069																							•	•

To remove screws with a damaged screw recess

Conical extraction screws: use counterclockwise to remove screws with a damaged screw recess.

Note: The conical tip of the extraction screw grasps the screw recess and the screw can be removed by turning counterclockwise.

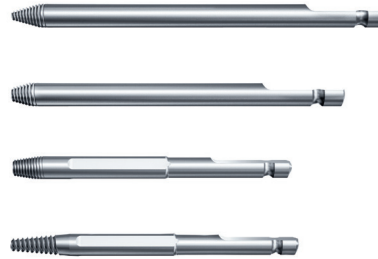

The table below shows screw diameter and geometry/recess size. It is not always possible to clearly allocate the extraction screw.

Note: Always use the extraction screw with the largest possible diameter.

Conical extraction screw for screw diameter (and drive recess)













		Screw diameter (and drive recess)																						
Recess																								
Conical extraction screws		1.5 mm (1.5 mm Hex)	2.0 mm (1.5 mm Hex)	2.0 mm (T6 StarDrive Recess)	2.4 mm (T8 StarDrive Recess)	2.7 mm (2.5 mm Hex)	2.7 mm (T8 StarDrive Recess)	2.7 mm (T15 StarDrive Recess)	3.5 mm (2.5 mm Hex)	3.5 mm (T15 StarDrive Recess)	3.9 mm (2.5 mm Hex)	3.9 mm (3.5 mm Hex)	4.0 mm (2.5 mm Hex)	4.0 mm (3.5 mm Hex)	4.0 mm (T25 StarDrive Recess)	4.5 mm (3.5 mm Hex)	4.9 mm (3.5 mm Hex)	5.0 mm (3.5 mm Hex)	5.0 mm (T25 StarDrive Recess)	6.0 mm (T25 StarDrive Recess)	6.5 mm (3.5 mm Hex)	4.0 mm Hex	T40 StarDrive Recess*	
	309.510	•	•	•	•		•	•		•		•		•		•	•	•				•	•	
	309.520					•		•		•	•	•	•	•	•	•	•	•	•	•	•			•
	309.530											•		•	•	•	•	•	•	•	•	•	•	•
	309.521					•	•	•	•	•			•											•

* EXPERT NAIL® System

To remove cannulated screws

The following table shows instruments that are required for the removal of broken cannulated screws. The instruments shown in parentheses are suitable if the break is in the shaft.

Extraction instruments for cannulated screws

		Screw diameter (and drive recess)									
Recess											
	Extraction instruments	2.4 mm (T8 StarDrive Recess)	3.0 mm (Cruciform)	3.0 mm HCS (T8 StarDrive)	3.5 mm (2.5 mm Hex)	4.0 mm (2.5 mm Hex)	4.5 mm (3.5 mm Hex)	5.0 mm locking (4.0 mm Hex)	6.5 mm (4.0 mm Hex)	7.0 mm (3.5 mm Hex)	7.3 mm (4.0 mm Hex)
	309.510	•		•			•			•	
	309.520				•	•	•	•		•	
	309.530						•		•	•	•
	309.521				•	•		•			
	309.521**								•		•
	309.510**						•		•	•	•
	387.34										•
	309.150	(•)	(•)								
	309.200			(•)	(•)						
	309.250	•	•	•		(•)		(•)			
	309.035		•	•	•	•	(•)	•			
	309.450					•	•	•	(•)	(•)	(•)
	309.065								•	•	
	309.090										
	309.190	(•)	(•)	(•)							
	309.290	•	•	•	(•)	(•)		(•)			
	309.039		•	•	•	•	(•)	•			
	309.490						•		(•)	(•)	(•)
	309.069								•	•	•

** Grips in the cannulation of the cannulated screw.

Preoperative Planning and Preparation

Preoperative planning

To ensure that the appropriate screw removal instruments are obtained, the surgeon should have the following information before implant removal:

- Implant manufacturer
- Implant type
- Time of implantation
- Material (steel, titanium)
- Recess geometry and dimension of the screws (hex, cruciform or StarDrive Recess)
- Screw diameter
- Any visible damage to the implant (eg, broken screw shaft)

1

Clean screw recess

Instrument

319.39 Sharp Hook

Optional instrument

03.900.001 Straight Sharp Hook

Before removing screws, clean the screw recess. Free the screw recess from ingrown scars and bone tissue using the sharp hook to ensure that the screwdriver can be fully inserted. Check the condition and the geometry of the recess of the exposed screwhead.

Note: Use the sharp hook to clean the recess if the soft tissue is not deep. If the screw is deep, use the straight sharp hook.

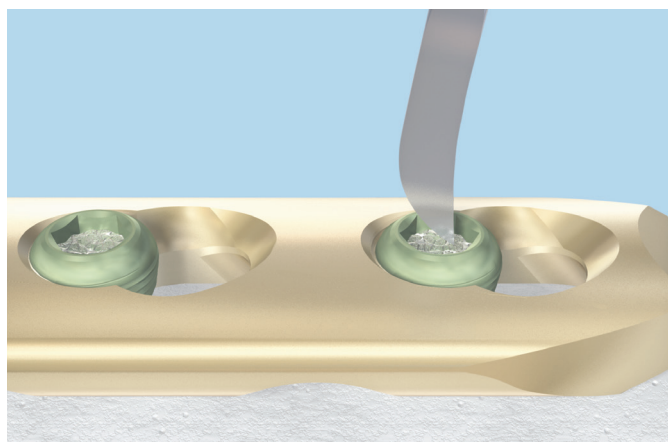
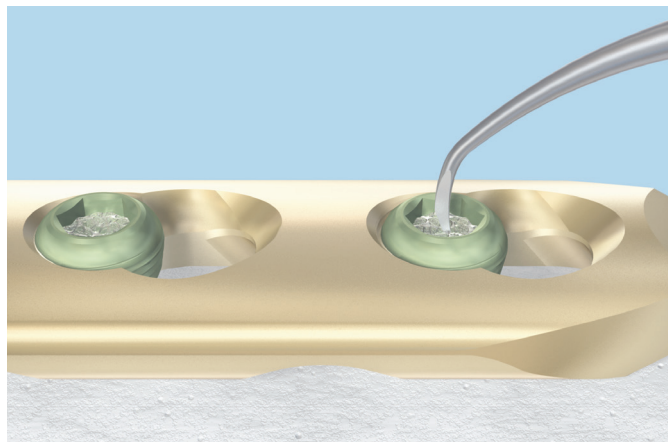

Removal of Intact Screws

1

Remove screw

Instruments

310.95	Handle, with mini quick coupling
or	
311.01	Handle, with mini quick coupling
311.431	Handle with quick coupling
393.105	Small Universal Chuck with T-Handle

Optional instruments

03.900.002	AO Coupling Extension Shaft
03.900.011	Small Screw Removal Forceps
03.900.013	Large Screw Removal Forceps

Connect the appropriate screwdriver shaft to a handle with quick coupling.

Note: If the screw is deep in the tissue, attach the AO coupling extension shaft.

Option

Instead of using the handle with quick coupling, a small universal chuck with T-handle can be used.

Connect the mini fragment screwdriver shafts to the handle with mini quick coupling.



1. Remove screw continued

Insert the screwdriver fully into the screw recess. If necessary, lightly tap the screwdriver with a hammer.

Note: Ensure that the screwdriver shafts are not damaged and are inserted on the same axis as the screw to be removed. The screw recess can be damaged if the screwdriver is not inserted straight or if it is blunt.

Unscrew the screw.

Note: To ensure that the loosened screw is not lost in the soft tissues, nor strips its thread in the bone, the screw can be held in position by extraction pliers for screws. Guide the extraction pliers along the screwdriver to the screwhead and grasp the screw directly behind the head.

When all screws have been removed, the plate/internal fixator can be removed.

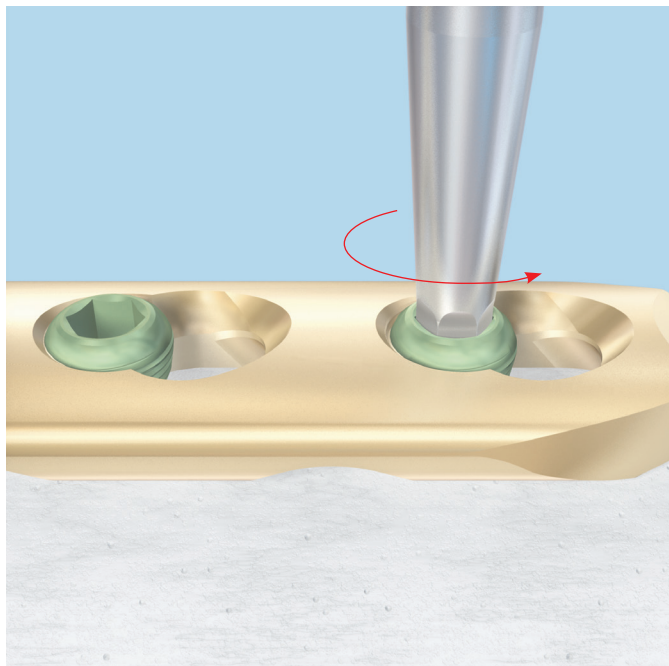
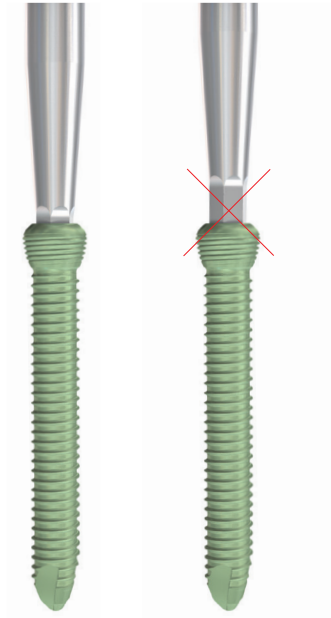

Removal of Broken Screws

Option 1: Screw shaft is exposed

1

Expose the screw shaft

Instrument

399.68 Gouge

Optional instrument

398.651 Narrow Screw Removal Pliers

If the screwhead is broken and the shaft is visible on the surface or slightly below the surface, use the gouge to remove the bone surrounding the screw shaft to approximately 5 mm in depth.

Note: The narrow screw removal pliers can be used to expose the screw shaft, by using the slightly opened pliers as an awl (sharp edges on the outside of the clamps).

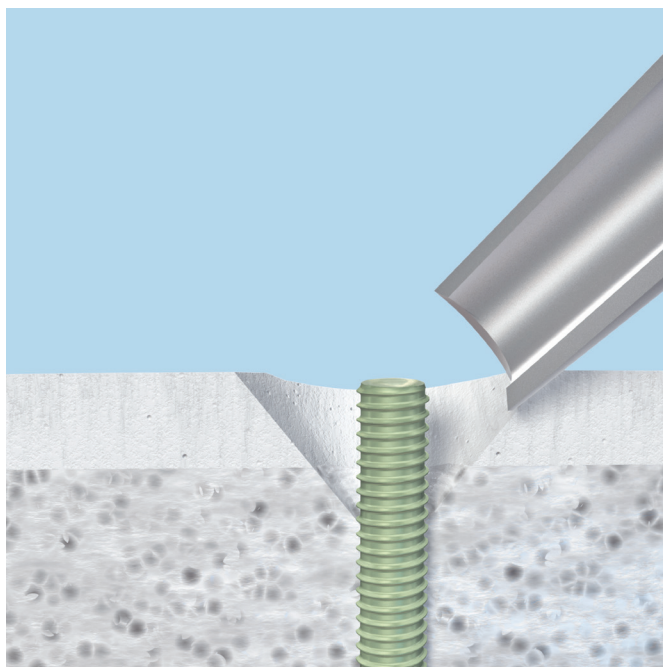

2

Remove screw

Instrument

398.65 Forceps for Screw Removal

Optional instrument

398.651 Narrow Screw Removal Pliers

Remove the screw with the forceps for screw removal.

Notes:

- Remove the screw stump by rotating it counterclockwise—do not pull or bend.
- The narrow screw removal pliers can be used to remove the screw and require less space to grasp the screw shaft than the forceps for screw removal.

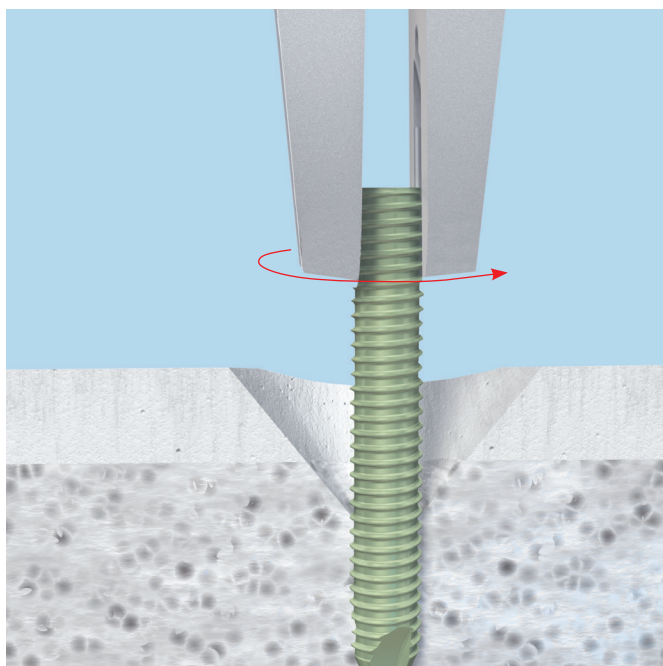

Option 2: Screw shaft is not exposed

1

Expose the screw shaft

Instruments

309.150– Hollow Reamers
309.450

310.89 Small Countersink

310.99 Large Countersink

311.431 Handle with quick coupling

Optional instrument

03.900.002 AO Coupling Extension Shaft

If the screwhead is broken and the shaft is not visible, or the screw fragment is deeply seated, create an opening with the small or large countersink, then use the hollow reamer.

The hollow reamer (complete) consists of three individual parts: reamer tube, centering pin, and shaft. To assemble the hollow reamer:

- 1 Connect the centering pin and the shaft (left-hand thread)
- 2 Screw the reamer tube over the centering pin (left-hand thread)

Note: There is no thread connection between the centering pin and the shaft for hollow reamers 309.150, 309.200, and 309.250. The reamer tube and the shaft are screwed together (left-hand thread).

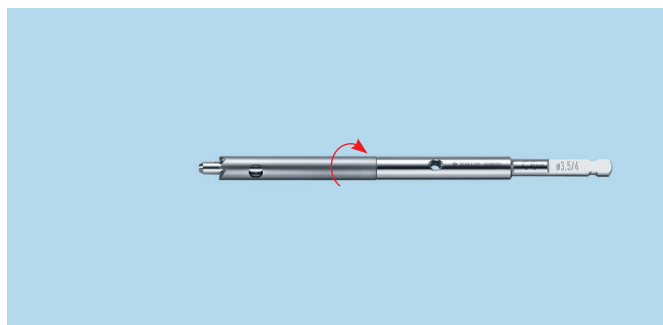
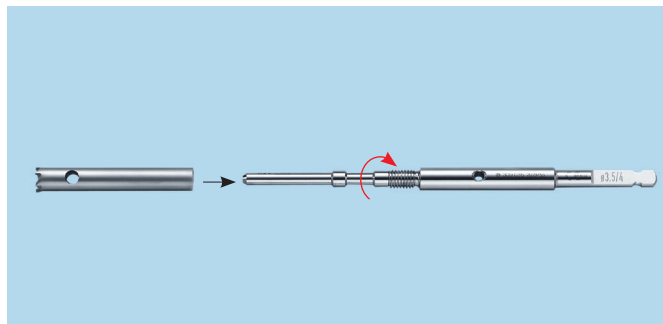
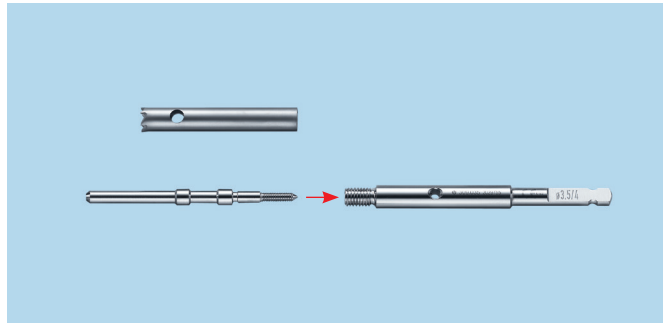

If the screw shaft has broken off less than approximately 5 mm below the bone surface, the hollow reamer can also be used without the centering pin. In this case, only connect the reamer tube and the shaft (left-hand thread).

Note: Only use instruments with sharp edges. It is possible to use the hollow reamer with power tools, but this should be done very carefully.

Connect the instruments with the handle with quick coupling.

Guide the centering pin into the canal of the broken screw and turn the hollow reamer counterclockwise. Remove the centering pin when it reaches the screw fragment. Then continue to turn the reamer without the centering pin, approximately 5 mm below the screw.

Note: If the screw is deep in the tissue, attach the AO coupling extension shaft.

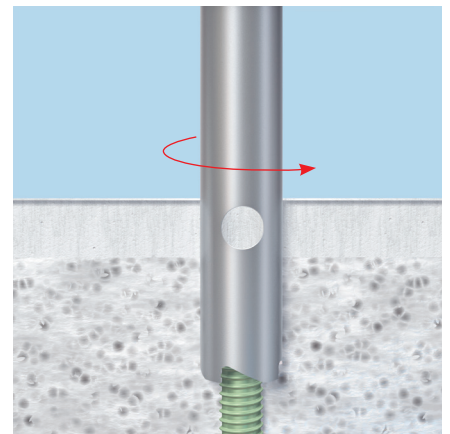
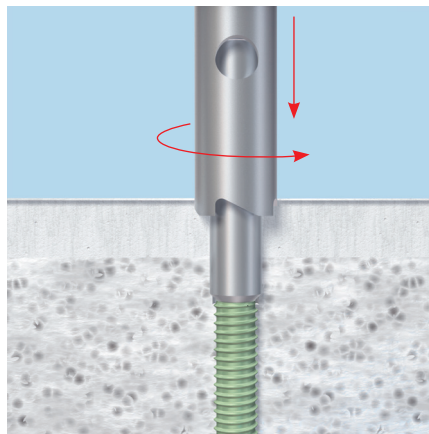
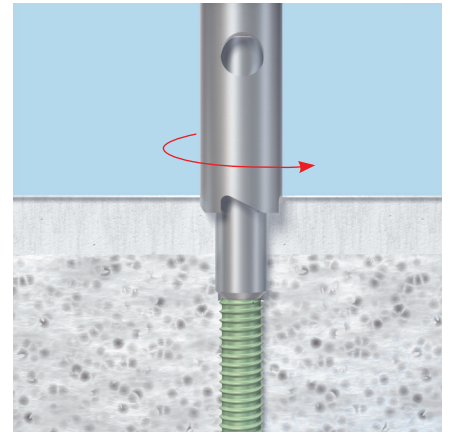
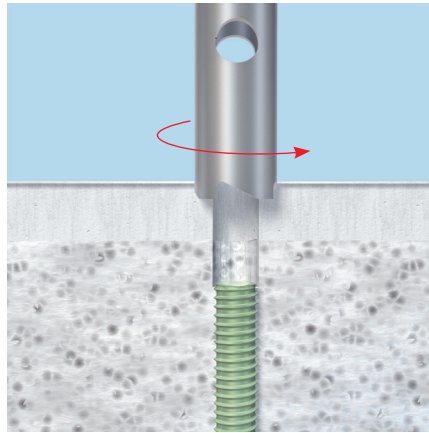

Option 2: Screw shaft is not exposed continued

2

Remove screw

Instruments

309.039– Extraction Bolts
309.290

311.431 Handle with quick coupling

Optional instrument

03.900.002 AO Coupling Extension Shaft

Connect the extraction bolt to the handle with quick coupling.

Note: If the screw is deep in the tissue, attach the AO coupling extension shaft.

Position the extraction bolt above the broken screw. Rotate counterclockwise while maintaining pressure and holding the extraction bolt as vertical as possible. This ensures a secure connection between the conical shape of the thread of the extraction bolt and the shaft of the screw. Turn counterclockwise until the screw shaft is completely removed.

Note: The hollow reamer and the extraction bolt are left-turning (to be turned counterclockwise). During insertion, ensure that enough axial pressure is exerted and maintain alignment with the axis of the screw.

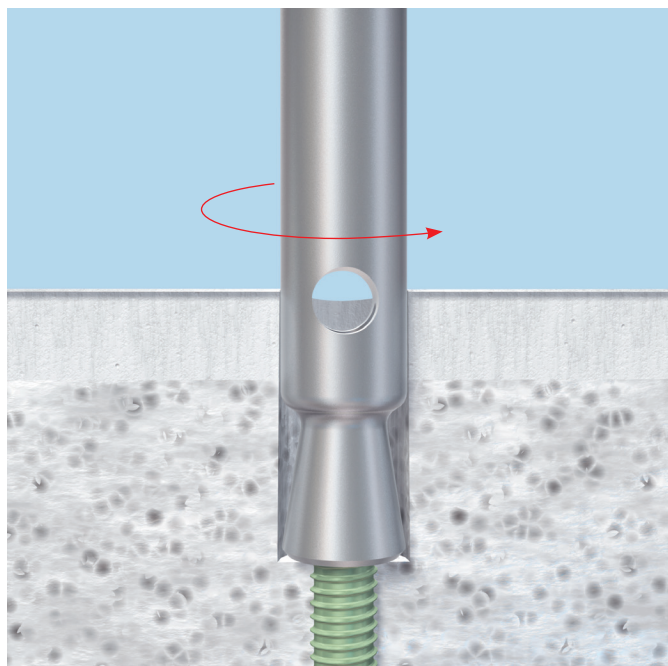
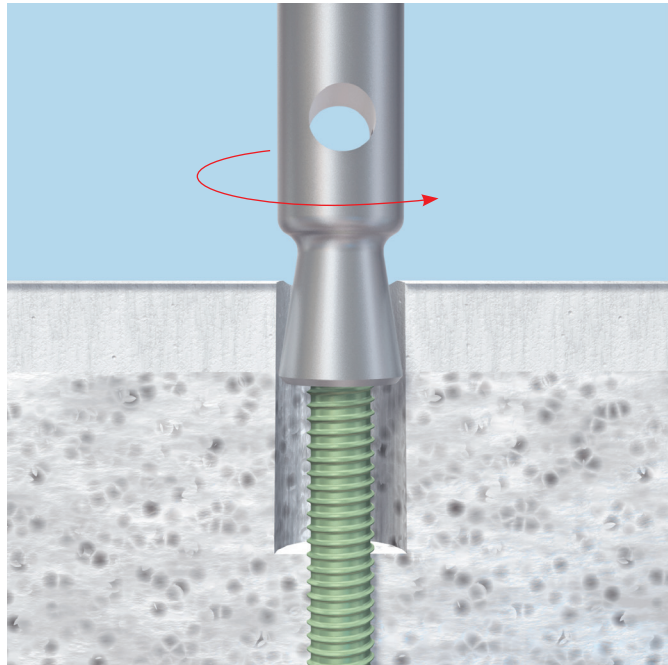

Removal of Screws with Damaged Recesses

Option 1: Screwdriver turns freely in the recess

1

Remove screw

Instruments

309.510– Conical Extraction Screws
309.530

311.431 Handle with quick coupling

Optional instrument

03.900.002 AO Coupling Extension Shaft

Connect the conical extraction screw to the handle with quick coupling.

Note: If the screw is deep in the tissue, attach the AO coupling extension shaft.

Insert the tip of the conical extraction screw into the screw recess and hold it as vertical as possible. Turn counterclockwise, exerting pressure, until the extraction screw grasps into the screw recess. Continue to turn counterclockwise to remove the screw.

Note: During insertion, ensure that enough axial pressure is exerted and maintain alignment with the axis of the screw. Only use sharp-edged extraction screws (recommendation: one extraction). Do not use extraction screws with power tools.

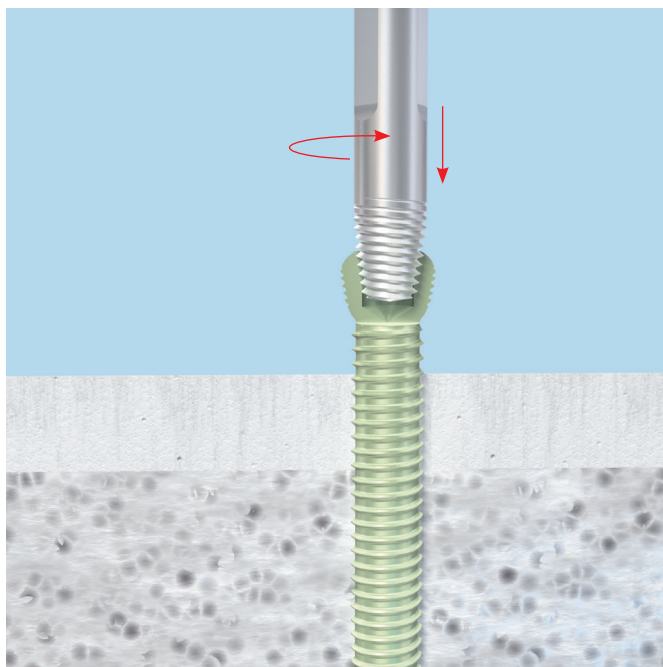

Option 2: Screwdriver and conical extraction screw turn freely in the recess

1

Remove screw

If the screwdriver and the conical extraction screw wear down the recess of the screw and turn freely in the recess, it may be possible to lightly predrill the screw recess to anchor the conical extraction screw deeper.

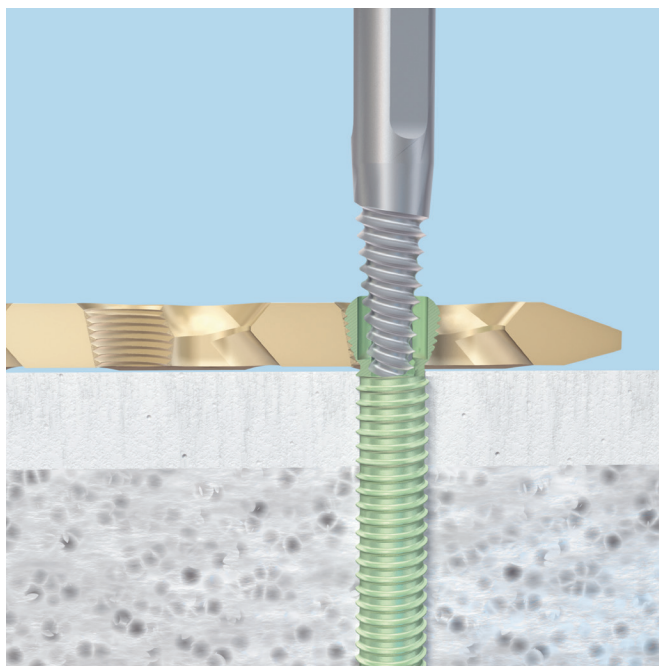
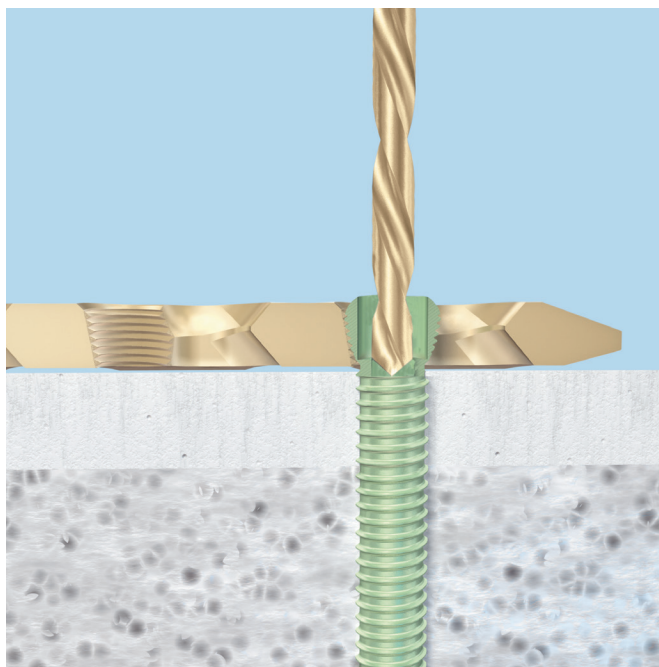

2**Prepare for drilling****Optional instruments**

03.607.025	2.5 mm Drill Sleeve Clip-on, for 03.607.110
03.607.035	3.5 mm Drill Sleeve Clip-on, for 03.607.110
03.607.040	4.0 mm Drill Sleeve Clip-on, for 03.607.110
03.607.048	4.8 mm Drill Sleeve Clip-on, for 03.607.110
03.607.060	6.0 mm Drill Sleeve Clip-on, for 03.607.110
03.607.110	Drill Suction Device
309.004S	4.0 mm Carbide Drill Bit, sterile
309.006S	6.0 mm Carbide Drill Bit, sterile
309.503S	2.5 mm High Speed Drill Bit, sterile
309.504S	3.5 mm High Speed Drill Bit, sterile
309.506S	4.8 mm High Speed Drill Bit, sterile

Drilling screws can cause drill chips that should be suctioned away. It is also important to cool the drill bit during the drilling process. The drill suction device allows efficient aspiration of the drill chips, while simultaneously cooling the drill bit.

Before drilling, attach the appropriate drill sleeve to the drill suction device. Then connect the drill suction device to the irrigation system and the vacuum pump. To release the drill sleeve, press the side flange.

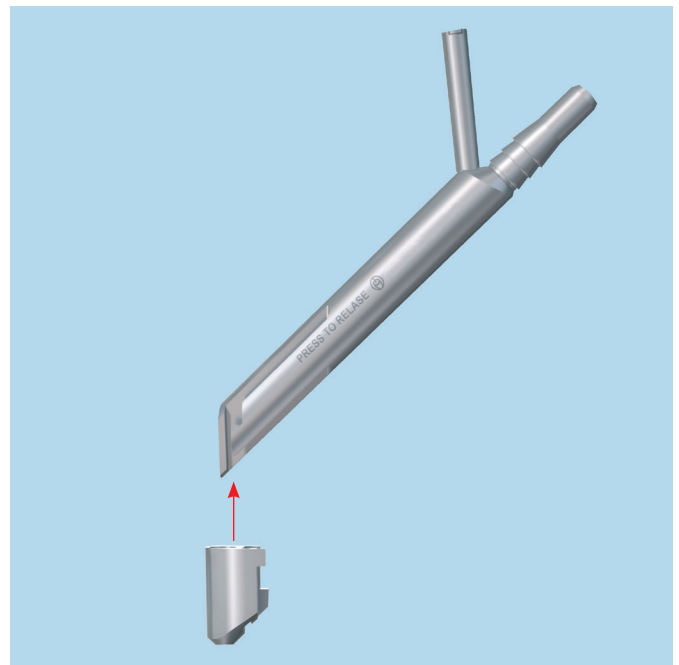

Option 2: Screwdriver and conical extraction screw turn freely in the recess continued

3

Drill screw recess

Optional instruments

03.607.040	4.0 mm Drill Sleeve Clip-on, for 03.607.110
03.607.060	6.0 mm Drill Sleeve Clip-on, for 03.607.110
03.607.110	Drill Suction Device
309.004S	4.0 mm Carbide Drill Bit, sterile
309.006S	6.0 mm Carbide Drill Bit, sterile

Switch on the rinsing equipment and the vacuum pump. Position the drill suction device on the relevant screw.

Insert the drill bit into the drill sleeve, start the drill, then begin drilling. Carefully predrill the screw recess.

Note: Do not interrupt the water supply. Ensure that the supply and waste hoses are not bent.

Notes for drilling with metal drill bits:

Precaution:

- Drill bits may not be reprocessed or resterilized. They are designed for single use only.
- Metal drill bits are hard and brittle. To prevent breakage, start drilling with the drill bit already revolving and maintain the chosen drill axis throughout the entire drilling process.

Note:

- When drilling, cool with the drill suction device and aspirate the drill chips.
- Refer to page 21 for selection of appropriate drill bit.

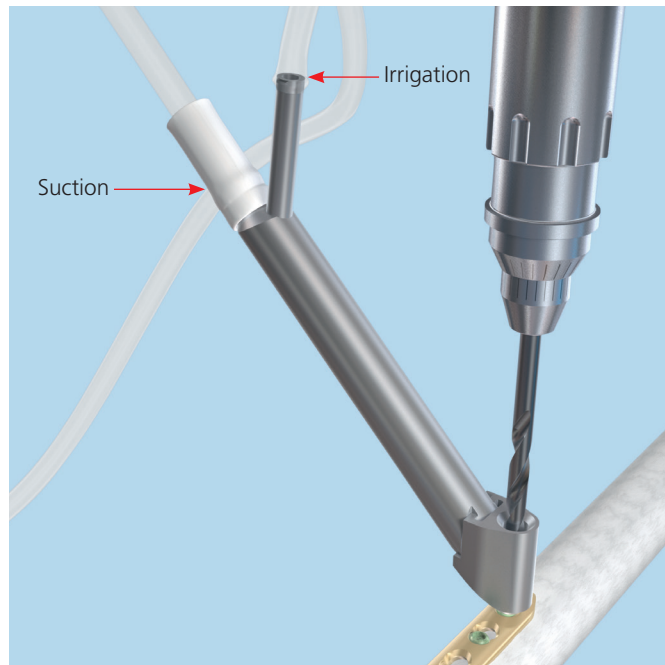

4

Remove screw

Instruments

309.510 – Conical Extraction Screws
309.530

393.105 Small Universal Chuck, with T-Handle

Remove the screw with the conical extraction screw, as described on page 13.

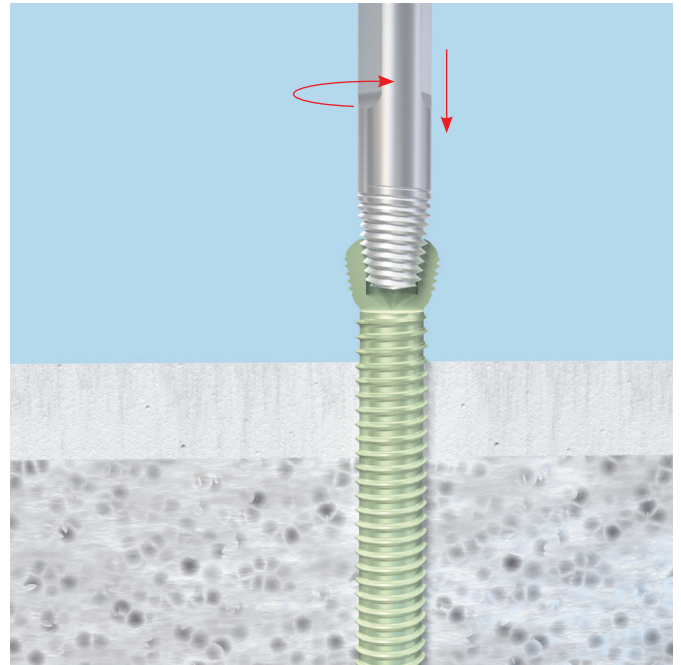

Removal of Jammed Screws

1

Remove broken instrument and screw

Instruments

319.39 Sharp Hook

398.65 Forceps for Screw Removal

If a broken instrument is in the recess, first attempt to remove the broken part of the instrument with a sharp hook and/or forceps for screw removal. If this attempt fails, proceed with the next step.

2

Prepare for drilling

Optional instruments

03.607.025	2.5 mm Drill Sleeve Clip-on, for 03.607.110
03.607.035	3.5 mm Drill Sleeve Clip-on, for 03.607.110
03.607.040	4.0 mm Drill Sleeve Clip-on, for 03.607.110
03.607.048	4.8 mm Drill Sleeve Clip-on, for 03.607.110
03.607.060	6.0 mm Drill Sleeve Clip-on, for 03.607.110
03.607.110	Drill Suction Device
309.004S	4.0 mm Carbide Drill Bit, sterile
309.006S	6.0 mm Carbide Drill Bit, sterile
309.503S	2.5 mm High Speed Drill Bit, sterile
309.504S	3.5 mm High Speed Drill Bit, sterile
309.506S	4.8 mm High Speed Drill Bit, sterile

Select the appropriate drill bit and attach it to the universal chuck of the power tool and tighten (see page 21).

If the screw is deep, the carbide drill bit extensions can be used.

Before drilling, attach the appropriate drill sleeve to the drill suction device. Then connect the drill suction device to the irrigation system and the vacuum pump. To release the drill sleeve, press the side flange.

Note: The use of the drill suction device allows efficient aspiration of the drill chips, while simultaneously cooling the drill bit.

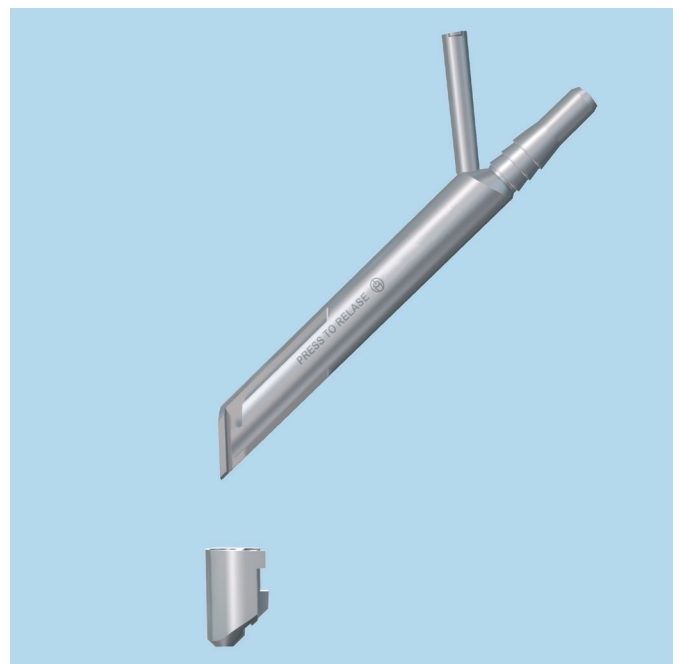
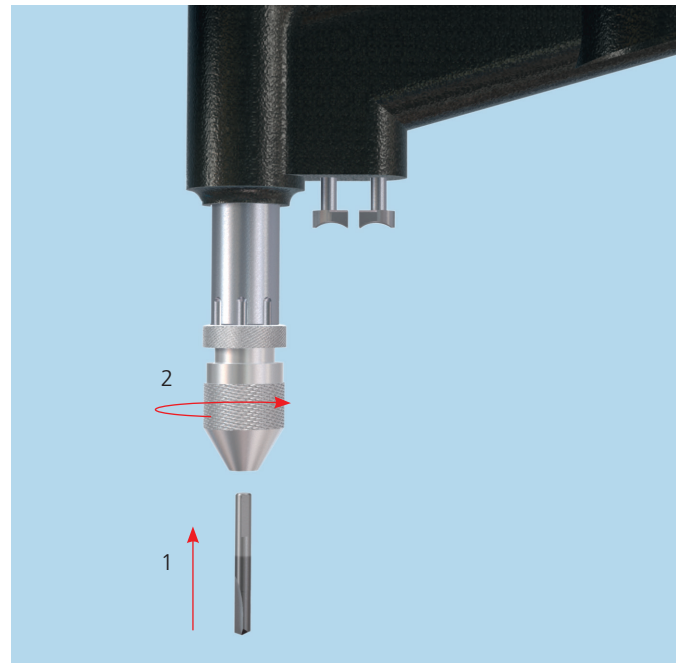

3

Drill off screwhead

Switch on the rinsing equipment and the vacuum pump. Position the drill suction device on the relevant screw.

Insert the drill bit into the drill sleeve, start the drill then begin drilling. Carefully drill off the screwhead.

Align the axis of the drill with axis of the screw and maintain this alignment throughout the drilling process. Drill until the screwhead is detached or removed from the screw shaft.

Note: Do not interrupt the water supply. Ensure that the supply and waste hoses are not bent.

Remove the plate when it is no longer held in place by any screws.

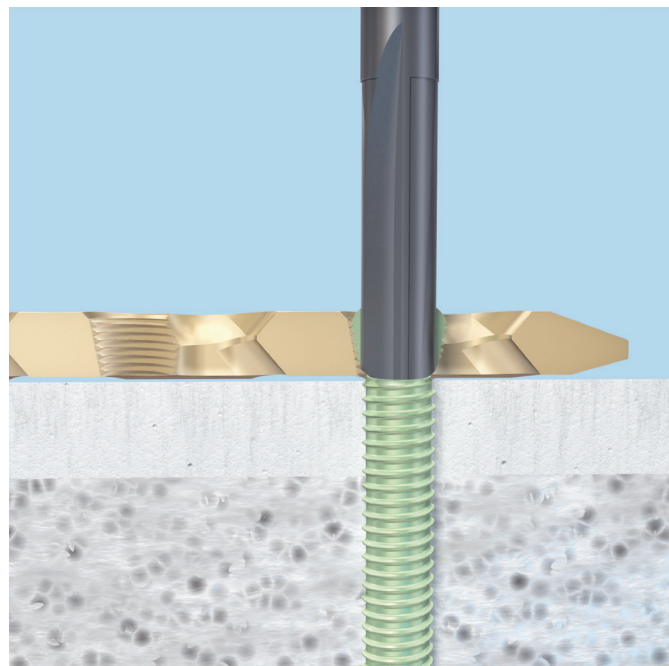
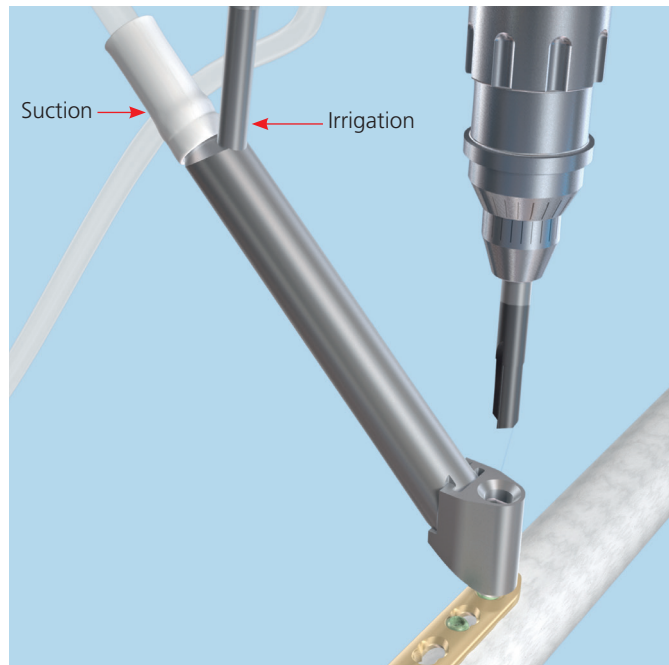

4

Remove remaining screw shaft

Proceed as for a broken screw.

Note: Select the carbide drill bit to drill out screws from titanium implants. To remove broken instruments from the screw recess (eg, tips of screwdrivers, extraction screws), only use the carbide drill bits.

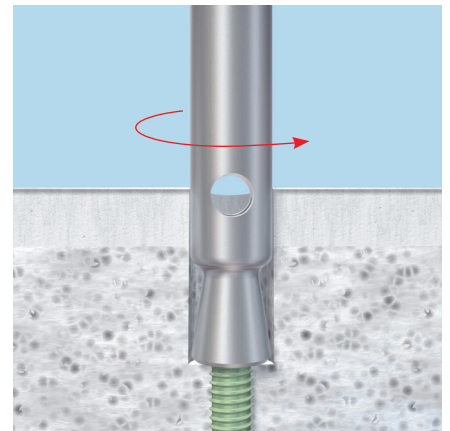
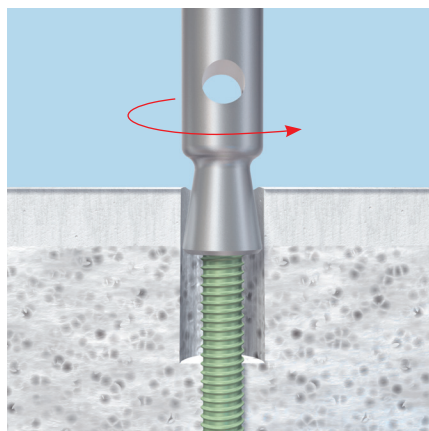
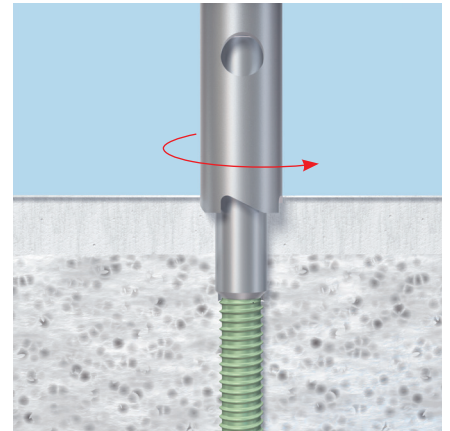
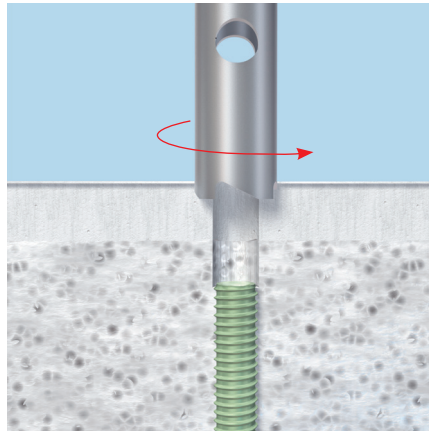

Screw sizes	Drill bits			Drill bits suitable for		
		Drill diameter	Drill type	Titanium*	Implant steel	Instrument steel
3.5 mm, 4.0 mm	309.503S	2.5 mm	High speed	++	++	-
3.5 mm, 4.0 mm, 4.5 mm, 5.0 mm	309.504S	3.5 mm	High speed	++	++	-
3.5 mm, 4.0 mm, 4.5 mm, 5.0 mm	309.004S	4.0 mm	Carbide	++	+	+
5.0 mm, 6.5 mm, 7.0 mm, 7.3 mm	309.506S	4.8 mm	High speed	++	++	-
5.0 mm, 6.5 mm, 7.0 mm, 7.3 mm	309.006S	6.0 mm	Carbide	++	+	+

- ++ good drilling properties
- + adequate drilling properties
- not recommended

*Commercially pure (CP) titanium and titanium alloys (Ti-6Al-7Nb and Ti-6Al-4V)

Instruments

03.607.104 4.0 mm Carbide Drill Bit Extension



03.607.106 6.0 mm Carbide Drill Bit Extension



03.607.110 Drill Suction Device



Drill Sleeve Clip-ons, for 03.607.110

03.607.025 2.5 mm
03.607.035 3.5 mm
03.607.040 4.0 mm
03.607.048 4.8 mm
03.607.060 6.0 mm



03.900.001 Straight Sharp Hook



03.900.002 AO Coupling Extension Shaft



03.900.011 Small Screw Removal Forceps



03.900.013 Large Screw Removal Forceps



Hollow Reamers, complete
 309.035 for 3.5 mm and 4.0 mm screws
 309.065 for 6.5 mm and 7.0 mm screws
 309.150 for 1.5 mm screws
 309.200 for 2.0 mm screws
 309.250 for 2.7 mm screws
 309.450 for 4.5 mm screws



Extraction Bolts
 309.039 for 3.5 mm and 4.0 mm screws
 309.069 for 6.5 mm and 7.0 mm screws
 309.090 for 1.5 mm screws
 309.190 for 2.0 mm screws
 309.290 for 2.7 mm screws
 309.490 for 4.5 mm and 5.0 mm screws



Conical Extraction Screws
 309.501 for threaded washers
 309.510 for 1.5 mm and 2.0 mm screws
 309.520 for 2.7 mm, 3.5 mm and 4.0 mm screws
 309.521 for 3.5 mm screws
 309.530 for 4.5 mm and 6.5 mm screws
 387.34 for 7.3 mm cannulated screws



310.89 Countersink, for 3.5 mm Cortex and 4.0 mm Cancellous Bone Screw



310.95 Handle, with mini quick coupling, stainless steel



310.99 Countersink, for 4.5 mm Cortex and 6.5 mm Cancellous Bone Screws



311.01 Handle, with mini quick coupling



311.431 Large Handle with quick coupling



StarDrive Screwdriver Shafts

03.900.042 T25

03.900.044 T40

313.822 1.3 mm, self-retaining

313.832 1.5 mm, self-retaining

313.842 2.0 mm, self-retaining

314.116 T15, self-retaining

314.119 T25, self-retaining

314.451 2.4 mm



313.93 Solid Hexagonal Screwdriver, 4.0 mm width across flats

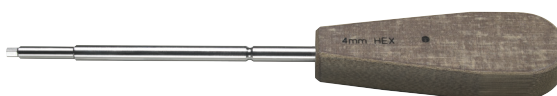

Cruciform Screwdriver Shafts
 03.900.022 2.4 mm
 313.991 1.0 mm, self-retaining
 313.992 1.3 mm, self-retaining
 313.993 1.5 mm, 2.0 mm, self-retaining
 314.465 for 3.0 mm cannulated screws



Hexagonal Screwdriver Shafts
 03.900.032 4.0 mm width across flats
 314.03 small, 2.5 mm width across flats
 314.15 large, 3.5 mm width across flats



314.13 Large Hexagonal Screwdriver with T-Handle

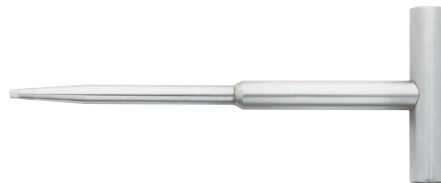

314.464 Cannulated Driver, for Threaded Washers, for 3.0 mm cannulated screws



319.39 Sharp Hook



393.105 Small Universal Chuck with T-Handle

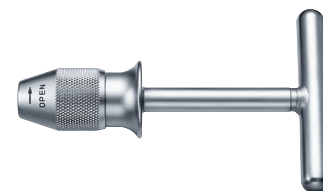

398.651 Narrow Screw Removal Pliers



398.65 Forceps, for broken screw removal



399.68 Hollow Gouge, for screw exposure



Also Available

Carbide Drill Bits, sterile
309.004S 4.0 mm
309.006S 6.0 mm



Spare Reamer Tubes
309.038 for Hollow Reamer (309.035)
309.068 for Hollow Reamer (309.065)
309.080 for Hollow Reamer (309.150)
309.180 for Hollow Reamer (309.200)
309.280 for Hollow Reamer (309.250)
309.480 for Hollow Reamer (309.450)



Spare Centering Pin
309.070 for Hollow Reamer (309.150)
309.170 for Hollow Reamer (309.200)
309.270 for Hollow Reamer (309.250)



309.370 for Hollow Reamer (309.035)
309.470 for Hollow Reamer (309.450)
309.670 for Hollow Reamer (309.065)



High Speed Drill Bits, sterile
309.503S 2.5 mm
309.504S 3.5 mm
309.506S 4.8 mm



Screw Removal Set (01.240.001)

Graphic Case

60.240.001 Graphic Case for Screw Removal Set

Instruments

- Drill Sleeve Clip-ons, for 03.607.110
- 03.607.025 2.5 mm
 - 03.607.035 3.5 mm
 - 03.607.040 4.0 mm
 - 03.607.048 4.8 mm
 - 03.607.060 6.0 mm
- Carbide Drill Bit Extensions
- 03.607.104 4.0 mm
 - 03.607.106 6.0 mm
- 03.607.110 Drill Suction Device
- 03.900.001 Straight Sharp Hook
- 03.900.002 AO Coupling Extension Shaft
- 03.900.011 Screw Removal Forceps, small
- 03.900.013 Screw Removal Forceps, large
- 03.900.022 2.4 mm Cruciform Screwdriver Shaft, 100 mm
- 03.900.032 4.0 mm Hexagonal Screwdriver Shaft, 100 mm
- 03.900.042 T25 StarDrive Screwdriver Shaft, 100 mm
- 03.900.044 T40 StarDrive Screwdriver Shaft, 100 mm
- Extraction Bolts
- 309.039 for 3.5 mm and 4.0 mm screws
 - 309.069 for 6.5 mm and 7.0 mm screws
 - 309.090 for 1.5 mm screws
 - 309.190 for 2.0 mm screws
 - 309.290 for 2.7 mm screws
 - 309.490 for 4.5 mm screws
- Hollow Reamers, complete
- 309.035 for 3.5 mm and 4.0 mm screws
 - 309.065 for 6.5 mm and 7.0 mm screws
 - 309.150 for 1.5 mm screws
 - 309.200 for 2.0 mm screws
 - 309.250 for 2.7 mm screws
 - 309.450 for 4.5 mm screws

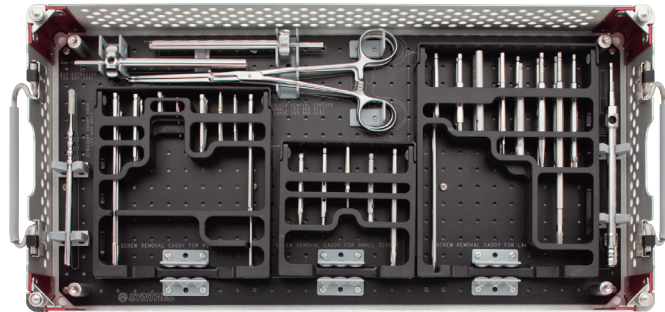

Note: For additional information, please refer to the package insert or www.e-ifu.com.

For detailed cleaning and sterilization instructions, please refer to www.depuySynthes.com/hcp/cleaning-sterilization or sterilization instructions, if provided in the instructions for use.

Instruments continued		387.34	Conical Extraction Screw
309.501	Conical Extraction Device, for threaded washers	393.105	Small Universal Chuck, with T-handle
	Conical Extraction Screws	398.65	Forceps, for broken screw removal
309.510	for 1.5 mm and 2.0 mm cortex screws	398.651	Narrow Screw Removal Pliers
309.520	for 2.7 mm and 3.5 mm cortex screws	399.68	Hollow Gouge, for broken screw exposure
309.521	for 3.5 mm screws		
309.530	for large screws and 4.9 mm bolts		
		Also Available	
310.89	Countersink, for 3.5 mm cortex and 4.0 mm cancellous bone screws	309.004S	4.0 mm Carbide Drill Bit, sterile
		309.006S	6.0 mm Carbide Drill Bit, sterile
			Spare Reamer Tubes
310.95	Handle, with mini quick coupling, stainless steel	309.038	for Hollow Reamer (309.035)
		309.068	for Hollow Reamer (309.065)
310.99	Countersink, for 4.5 mm cortex screws	309.080	for Hollow Reamer (309.150)
311.01	Handle, with mini quick coupling	309.180	for Hollow Reamer (309.200)
311.431	Large Handle, with quick coupling	309.280	for Hollow Reamer (309.250)
	Screwdriver Blades, self-retaining, StarDrive, short	309.480	for Hollow Reamer (309.450)
			Spare Centering Pins
313.822	1.3 mm	309.070	for Hollow Reamer (309.150)
313.832	1.5 mm	309.170	for Hollow Reamer (309.200)
313.842	2.0 mm	309.270	for Hollow Reamer (309.250)
313.93	4.0 mm Hexagonal Screwdriver	309.370	for Hollow Reamer (309.035)
	Cruciform Screwdriver Shafts, self-retaining	309.470	for Hollow Reamer (309.450)
313.991	1.0 mm	309.670	for Hollow Reamer (309.065)
313.992	1.3 mm		High Speed Drill Bits, sterile
313.993	1.5 mm/2.0 mm	309.503S	2.5 mm
314.03	Small Hexagonal Screwdriver Shaft	309.504S	3.5 mm
314.116	StarDrive Screwdriver Shaft, quick coupling, T15	309.506S	4.8 mm
314.119	StarDrive Screwdriver Shaft, T25, self-retaining, 165 mm		
314.13	Large Hexagonal Screwdriver, with T-handle		
314.15	Large Hexagonal Screwdriver Shaft		
314.451	2.4 mm StarDrive Screwdriver Shaft		
314.464	Cannulated Driver for Threaded Washers, for 3.0 mm cannulated screws		
314.465	Cruciform Screwdriver Shaft		
319.39	Sharp Hook		

Limited Warranty and Disclaimer: DePuy Synthes products are sold with a limited warranty to the original purchaser against defects in workmanship and materials. Any other express or implied warranties, including warranties of merchantability or fitness, are hereby disclaimed.

Please also refer to the package insert(s) or other labeling associated with the devices identified in this surgical technique for additional information.

CAUTION: Federal Law restricts these devices to sale by or on the order of a physician.

Some devices listed in this technique guide may not have been licensed in accordance with Canadian law and may not be for sale in Canada. Please contact your sales consultant for items approved for sale in Canada.

Not all products may currently be available in all markets.



Manufactured or distributed by:

Synthes USA Products, LLC
1302 Wrights Lane East
West Chester, PA 19380

Synthes USA, LLC
1101 Synthes Avenue
Monument, CO 80132

Synthes GmbH
Luzernstrasse 21
4528 Zuchwil, Switzerland

To order (USA): 800-523-0322

To order (Canada): 844-243-4321

Note: For recognized manufacturer, refer to the product label.

www.depuysynthes.com