

# TOMOFIX™ Medial High Tibial Plate (MHT)

For fixation of osteotomies of the Proximal Tibia

## Surgical Technique



---

 Image intensifier control

This description alone does not provide sufficient background for direct use of DePuy Synthes products. Instruction by a surgeon experienced in handling these products is highly recommended.

**Processing, Reprocessing, Care and Maintenance**

For general guidelines, function control and dismantling of multi-part instruments, as well as processing guidelines for implants, please contact your local sales representative or refer to:

<http://emea.depuysynthes.com/hcp/reprocessing-care-maintenance>

For general information about reprocessing, care and maintenance of DePuy Synthes reusable devices, instrument trays and cases, as well as processing of DePuy Synthes non-sterile implants, please consult the Important Information leaflet (SE\_023827) or refer to:

<http://emea.depuysynthes.com/hcp/reprocessing-care-maintenance>

# Table of Contents

---

<b>Introduction</b>	TomoFix Medial High Tibial Plate (MHT)	2
	The AO Principles of Fracture Management	4

---

<b>Surgical Technique</b>	Open Wedge Surgical Technique	5
	• Preparation and Approach	5
	• Osteotomy	12
	• Positioning and Fixation of the Plate	32
	• Postoperative Treatment and Implant Removal	50
	Closed Wedge Surgical Technique	51
	• Preparation	51
• Osteotomy	55	

---

<b>Product Information</b>	Plates	57
	Screws	59
	Kirschner wires	60
	Instruments	61
	Optional Instruments	64
	Cases	65
	Optional Case	66

---

<b>MRI Information</b>	67
------------------------	----

- Notes
- ▲ Precautions
- ▲ WARNINGS

# TomoFix Medial High Tibial Plate (MHT)

For fixation of osteotomies of the Proximal Tibia

## Overview

---

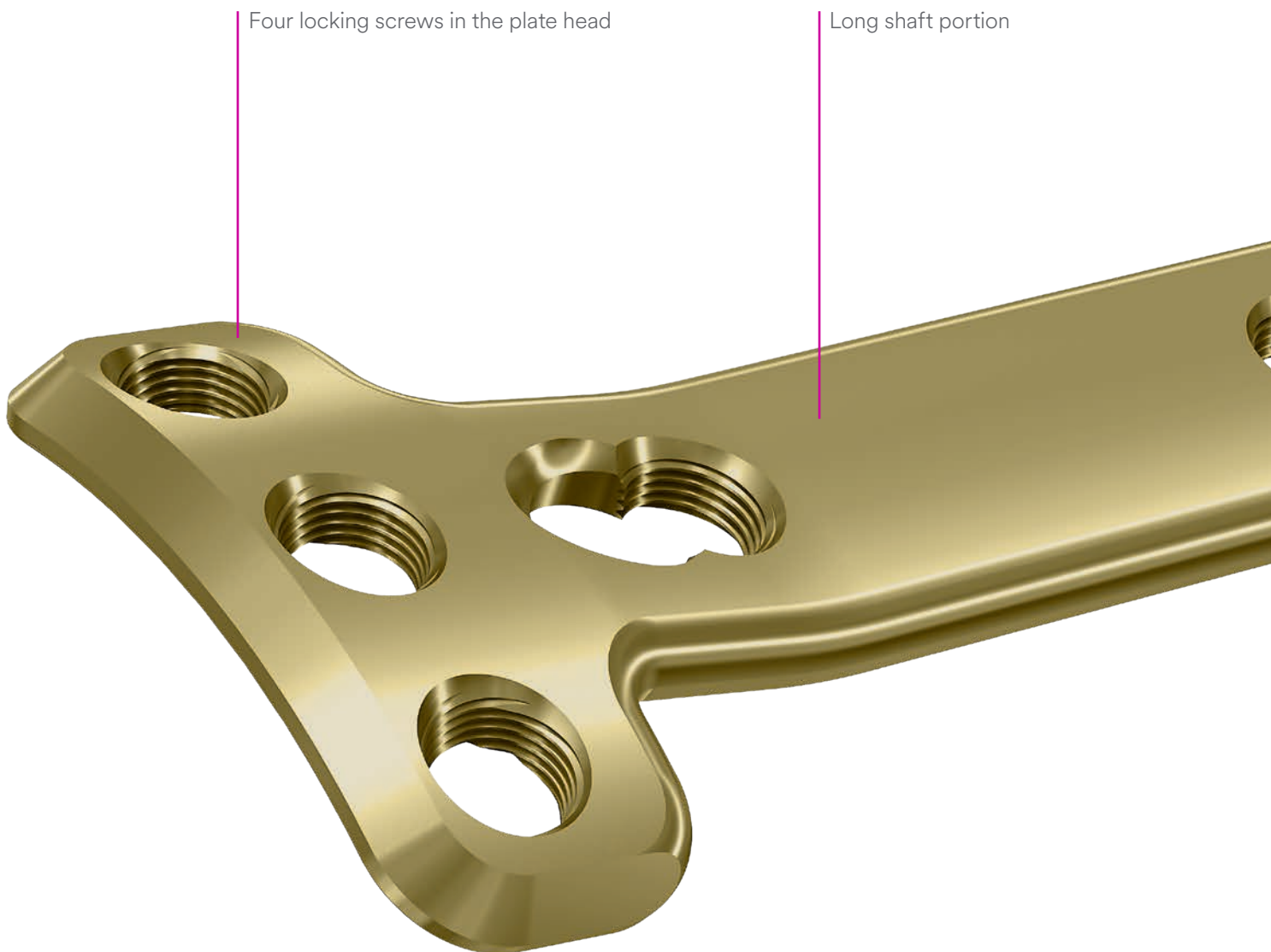

This surgical technique will explain the procedure of an open and closed wedge osteotomy.

TomoFix Plate Implants are based on locking compression plate (LCP) principles. The fixed-angle locking holes provide multiple fixed-angle constructs throughout the plate, facilitating retention of screws in the plate and in cortical bone.

**Intended Use, Indications, Contraindications can be found in the corresponding system Instructions for Use.**

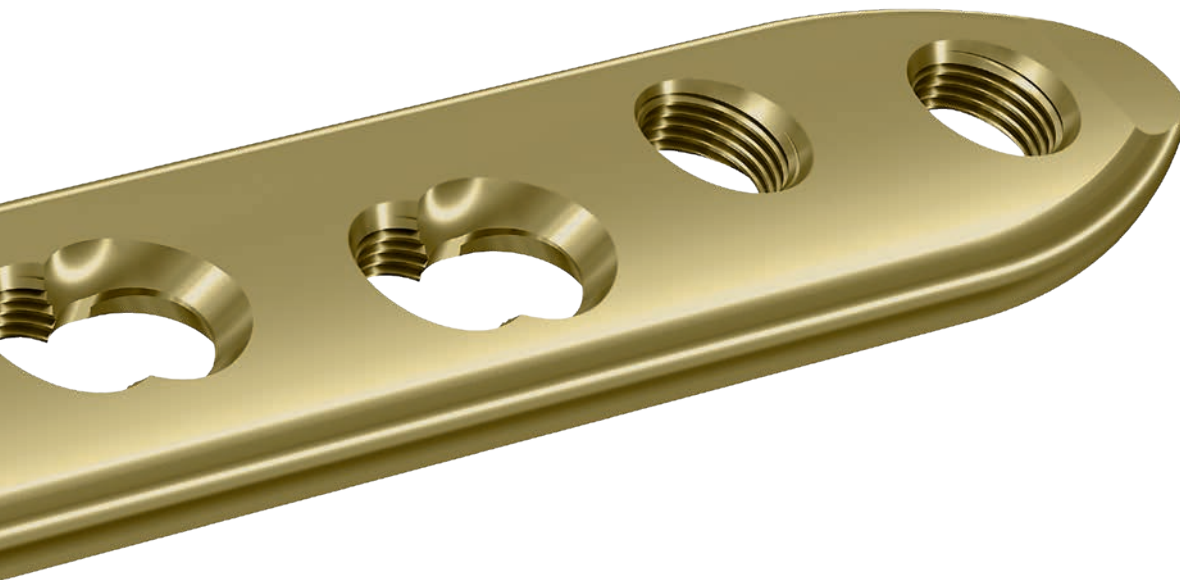

Tapered, rounded tip

## TomoFix Knee Osteotomy System



### TomoFix Medial High Tibia and Medial High Tibia Small Stature Plate

- Available in standard, small and anatomical stature versions



### TomoFix Lateral High Tibia Plate

- Fixed-angle construct
- Available in right and left versions



### TomoFix Medial Distal Femur Plate

- Fixed-angle construct
- Available in right and left versions



### TomoFix Lateral Distal Femur Plate

- Fixed-angle construct
- Available in right and left versions

# The AO Principles of Fracture Management

## Mission

The AO's mission is promoting excellence in patient care and outcomes in trauma and musculoskeletal disorders.

### AO Principles<sup>1,2</sup>

1.



Fracture reduction and fixation to restore anatomical relationships.

2.

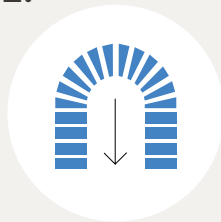

Fracture fixation providing absolute or relative stability, as required by the “personality” of the fracture, the patient, and the injury.

3.



Preservation of the blood supply to soft-tissues and bone by gentle reduction techniques and careful handling.

4.

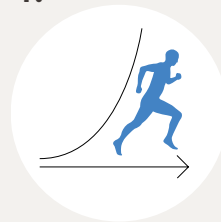

Early and safe mobilization and rehabilitation of the injured part and the patient as a whole.

<sup>1</sup> Müller ME, Allgöwer M, Schneider R, Willenegger H. Manual of Internal Fixation. 3rd ed. Berlin, Heidelberg New York: Springer 1991.

<sup>2</sup> Rüedi TP, RE Buckley, CG Moran. AO Principles of Fracture Management. 2nd ed. Stuttgart, New York: Thieme. 2007.

# Open Wedge Surgical Technique

## Preparation and Approach

### 1. Preoperative Planning

A precise preoperative plan is crucial to the success of this procedure. The recommended method for planning is that of Miniaci<sup>1</sup>. It must be done on the basis of the weight-bearing x-ray of the full leg in AP view, either on paper or at a digital workstation.

- Determine the mechanical axis of the leg: Draw a straight line from the center of the femoral head to the center of the ankle joint.
- Draw the new weight-bearing line from the center of the femoral head, passing the joint line through the desired position.
- Determine a hinge point (h). Generally the hinge point should be chosen on the lateral cortex and at the upper 1/3 proximal fibular head.

#### ■ Note:

The optimal position of the hinge point may vary according to patient specific anatomy.

Rotate the leg 30° internally to identify the optimal hinge point. The lateral hinge point should be within the proximal 1/3 of the fibular head (2).

- Connect the hinge point (h) with the center of the ankle joint (a). Rotate the connecting line h-a like a circle until it crosses the new weight bearing line. Connect the crossing point (b) with the hinge point h. The angle between the connecting line h-a and h-b is the angle of opening ( $\alpha$ ). Transfer the opening angle ( $\alpha$ ) to the level of the planned osteotomy. The height at the medial cortex (o) is the height of opening. (1)

#### ■ Note:

If the height is measured intraoperative it should be calculated as height of opening plus thickness of the saw blade (e.g. 0.9 mm).

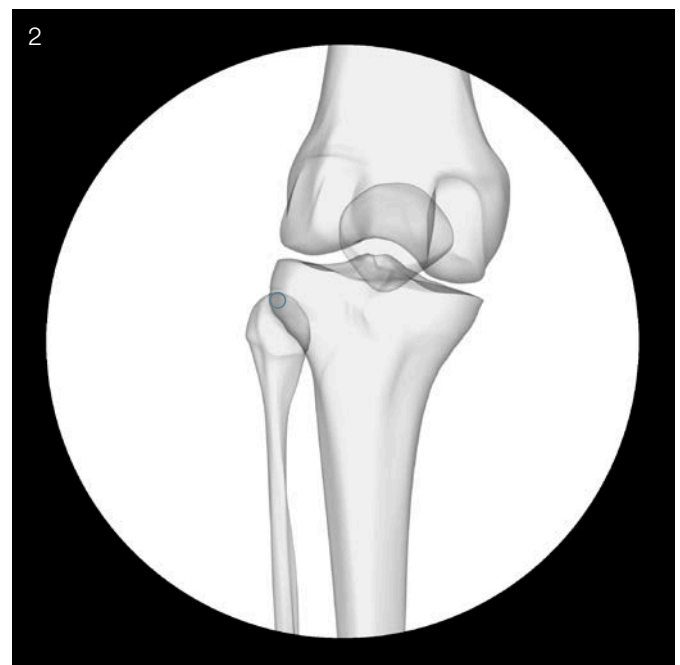
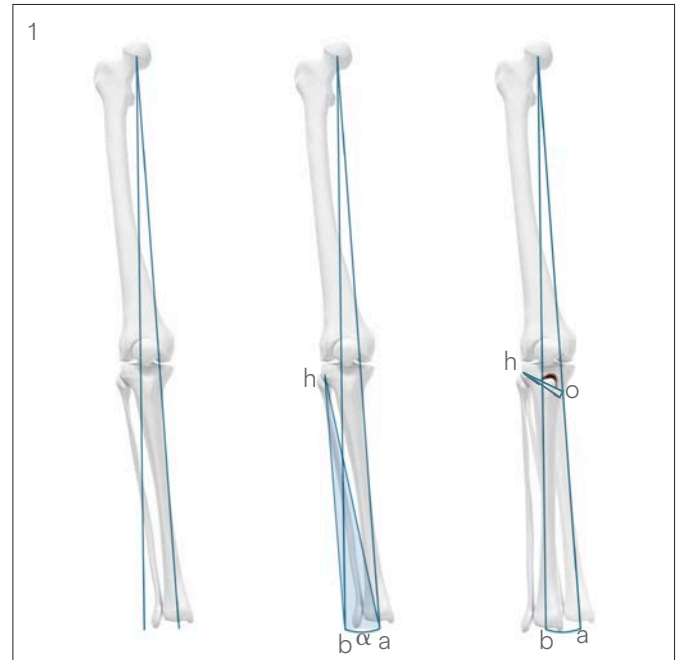

<sup>1</sup>Elson DW, Petheram TG, Dawson MJ. High reliability in digital planning of medial opening wedge high tibial osteotomy, using Miniaci's method. *Knee Surg Sports Traumatol Arthrosc.* 2015; 23: 2041-2048

Determine the entry point of the transverse osteotomy. It lies just above the pes anserinus. Make sure there is still enough space for the proximal part of the TomoFix plate (holes A-D), so that the screw in hole D can be inserted without protruding into the opening gap. Depending on the determined opening angle and the length of the osteotomy cut (mediolateral diameter of the osteotomy) the corresponding opening height can be derived from Hernigou's trigonometric chart.

## Trigonometric chart

		Correction Angle															
		4°	5°	6°	7°	8°	9°	10°	11°	12°	13°	14°	15°	16°	17°	18°	19°
Mediolateral diameter of the osteotomy (mm)	50 mm	3	4	5	6	7	8	9	10	10	11	12	13	14	15	16	16
	55 mm	4	5	6	7	8	9	10	10	11	12	13	14	15	16	17	18
	60 mm	4	5	6	7	8	9	10	11	12	14	15	16	17	18	19	20
	65 mm	5	6	7	8	9	10	11	12	14	15	16	17	18	19	20	21
	70 mm	5	6	7	8	10	11	12	13	15	16	17	18	20	21	22	23
	75 mm	5	6	8	9	10	12	13	14	16	17	18	20	21	22	24	25
	80 mm	6	7	8	10	11	13	14	15	17	18	19	21	22	24	25	26

### ■ Note:

These instructions alone do not replace in-depth training in planning for osteotomies and only serve as a general guideline.



## 2. Prepare the implant

### Instruments and implants

312.924	Guiding Block for TomoFix Tibial Head Plate, small, medial, proximal
and 440.831S	TomoFix Tibial Head Plate, small, medial, proximal, shaft 4 holes, head 4 holes, length 112 mm, Commercially Pure Titanium, sterile
or 312.926	TomoFix Guiding Block for TomoFix Tibial Head Plate, medial, proximal
and 440.834S	TomoFix Tibial Head Plate, medial, proximal, 4 holes, Commercially Pure Titanium, sterile
or 312.928	TomoFix Guiding Block for TomoFix Tibial Head Plate, anatomical, proximal, medial, left
and 440.837S	TomoFix Tibial Head Plate, anatomical, medial, proximal, left, head 4 holes, length 112 mm, Commercially Pure Titanium, sterile
or 312.929	TomoFix Guiding Block for TomoFix Tibial Head Plate, anatomical, proximal, medial, right
and 440.838S	TomoFix Tibial Head Plate, anatomical, medial, proximal, right, head 4 holes, length 112 mm, Commercially Pure Titanium, sterile
323.042	LCP Drill Sleeve 5.0, for Drill Bits Ø 4.3 mm
413.309	LCP Spacer Ø 5.0 mm, length 2 mm, Titanium Alloy (TAN)

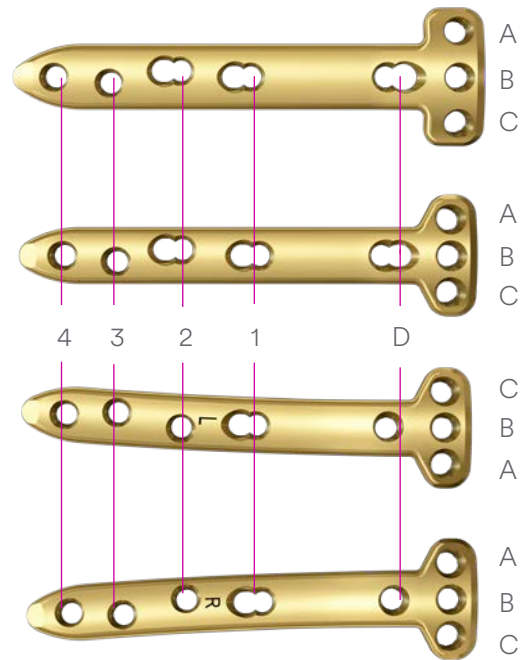

Choose the corresponding guiding block for either the standard, small or TomoFix plate. The plate has a left and right version. The guiding block is marked with L or R accordingly.

Place the guiding block on the plate. The guiding block serves as an aid for attaching the LCP drill guides and should be removed after the drill guides have been attached.

Screw in and tighten a LCP drill guide into holes A, B and C. Insert a LCP spacer  $\varnothing$  5.0 mm into hole D and hole 4.

■ **Notes:**

- Using spacers facilitates free movement of the pes anserinus underneath the plate as well as for bending of the plate.
- The anatomical TomoFix plates (440.837S, 440.838S) are provided contoured and should not be bent prior to implantation.

### 3. Positioning of patient

Perform the surgery with the patient in a supine position. (1)

Position the patient so that the hip, knee and ankle joint can be visualized with the image intensifier. Lower the contralateral leg at the hip joint to facilitate access to the medial proximal tibia.

The sterile draping also exposes the iliac crest so that the leg axis can be checked intraoperatively. A sterile tourniquet can be used, but is not mandatory.

#### ■ Notes:

- Allow enough space so that the leg can later be positioned in full extension as the intraoperative verification of the weight-bearing line has to be done with the leg in full extension.
- Attach a lateral support and foot pad to the operating table so that the leg can be easily positioned in 90° flexion and in full extension. (2)

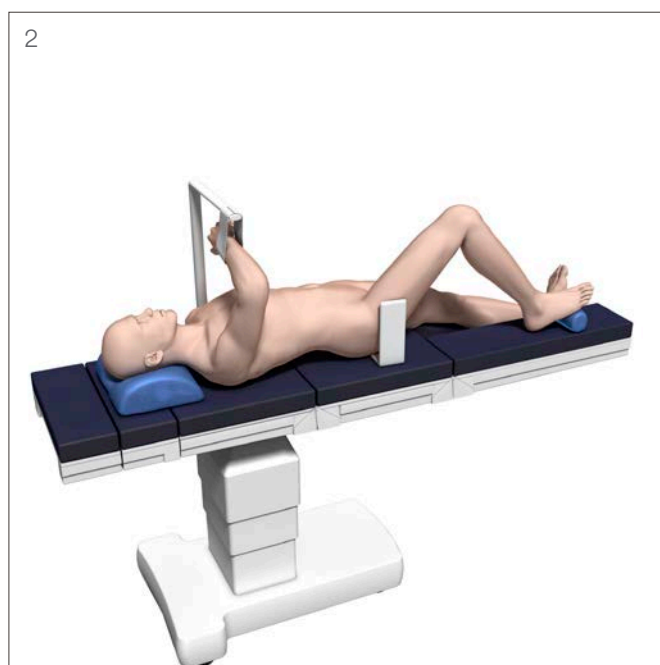
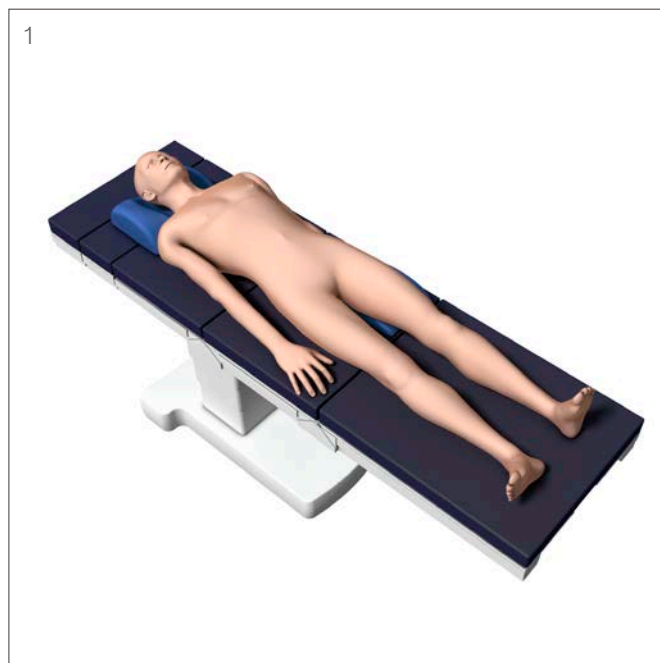

#### 4. Approach

Position the leg in full extension. Mark the anatomic landmarks (medial joint line, cranial border of pes anserinus, course of the medial collateral ligament, and tibial tuberosity) on the skin. Make a 6–8 cm longitudinal skin incision. The incision should begin one centimeter below the joint line and extending to the pes anserinus tendons (1). Alternatively the approach can also be made with the leg in flexion.

First, divide the subcutaneous tissues and the fascia at the cranial border of the pes anserinus. Retract the pes tendons distally. The anterior border of the superficial layer of the medial collateral ligament (MCL) now comes into view (2). Pass a periosteal elevator under the ligament that is then lifted from the tibia. Detach the long fibers of the superficial layer of the distal MCL from the tibia with a scalpel until the posterior ridge of the tibia is exposed.

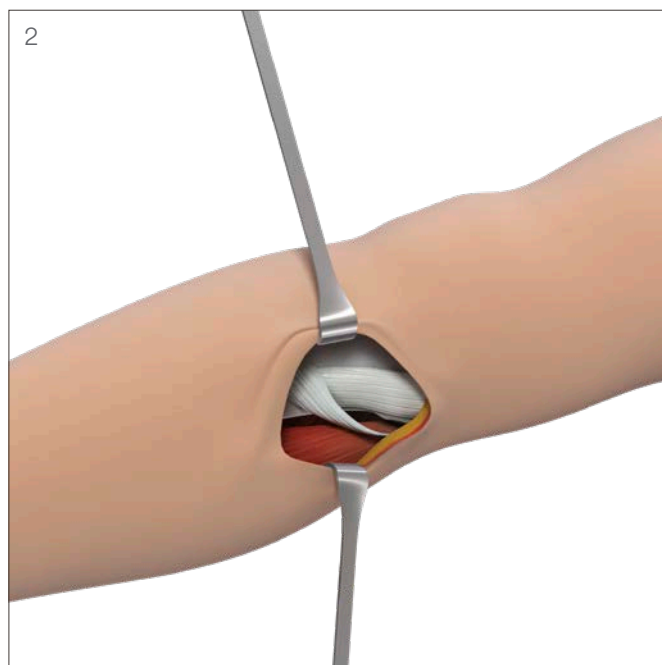
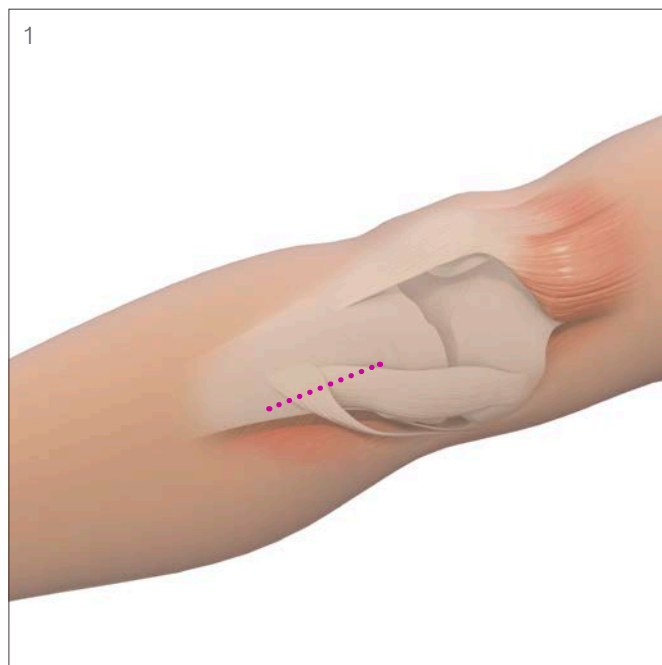

Insert the radiolucent retractor behind the tibia. Expose the insertion of the patellar tendon into the tibial tuberosity at the anterior edge of the incision (3). Define the cross point and the transverse cut.

■ **Notes:**

- The distal insertion of the patellar tendon must be clearly visualized to allow determination of the endpoint of the anteriorly ascending and transversal cut (crossing point) of the biplanar osteotomy later on.
- When defining the transverse cut use a TomoFix plate as reference to make sure that hole D is proximal of the osteotomy. (4)
- For a better intensifier view, the retractor can be removed after releasing the superficial layer of the medial collateral ligament (MCL).

▲ **Precaution:**

During the dissection, make sure that the dermal branches of the saphenous nerve are not damaged.

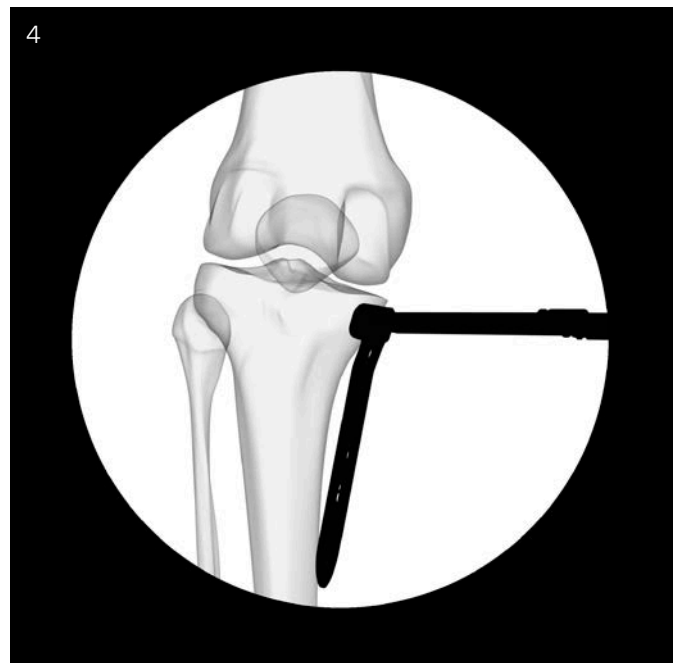

## Osteotomy

### 1. Determine the position and conduct the biplanar osteotomy

Position the leg in full extension and adjust the knee joint exactly into AP view under fluoroscopy. Align the medial and lateral compartments in AP projection. Rotate the leg in a position which locates the patella exactly anteriorly (one third of the fibular head is then usually covered by the tibia). (1)

#### ▲ Precaution:

A correct view of the tibia is crucial to ensure the proper orientation of the osteotomy.

Choose from the following options:

#### 1a.

Determine the position and conduct the biplanar osteotomy with a free hand technique.

#### 1b.

Determine the position and conduct the biplanar osteotomy with optional instruments.



## 1a. Determine the position and conduct the biplanar osteotomy with a free hand technique

### Kirschner wires

310.243	Guide Wire Ø 2.5 mm with drill tip, length 200 mm, Stainless Steel
or	
292.260	Kirschner Wire Ø 2.5 mm with trocar tip, length 280 mm, Stainless Steel

### Instruments

519.105	Saw Blade 70/49×20×0.6/0.4 mm, for Oscillating Saw with AO/ASIF Coupling
519.108	Saw Blade 116/95×25×0.9/0.8 mm, for Oscillating Saw with AO/ASIF Coupling

Place two 2.5 mm Kirschner wires into the tibia metaphysis under image intensification to mark the direction of the osteotomy. Both wires must run in parallel and aim towards the hinge point which was previously defined as part of the preoperative plan. (1)

The wires must end exactly at the lateral tibial cortex. Place the first posterior wire at the cranial border of the pes-anserinus just in front of the posterior tibial ridge. Place the second wire about 2 cm anterior and parallel to the first wire. When placing the two wires, it is important to ensure that there is sufficient space cranial to the saw cut for the four locking screws A, B, C and D in the Tomo-Fix plate, leaving at least 30 mm of distance to the ridge of the medial tibial plateau.

### ▲ Precaution:

To maintain the inclination of the tibial slope, the wires must run at the same angle to the tibial plateau (a). Performing the ascending osteotomy cut parallel to the anterior cortex of the tibial shaft (b; at a resulting angle of around 110° to the transverse osteotomy cut) is supposed to ensure good bony contact in the area of the ascending cut, after opening the osteotomy. (2)

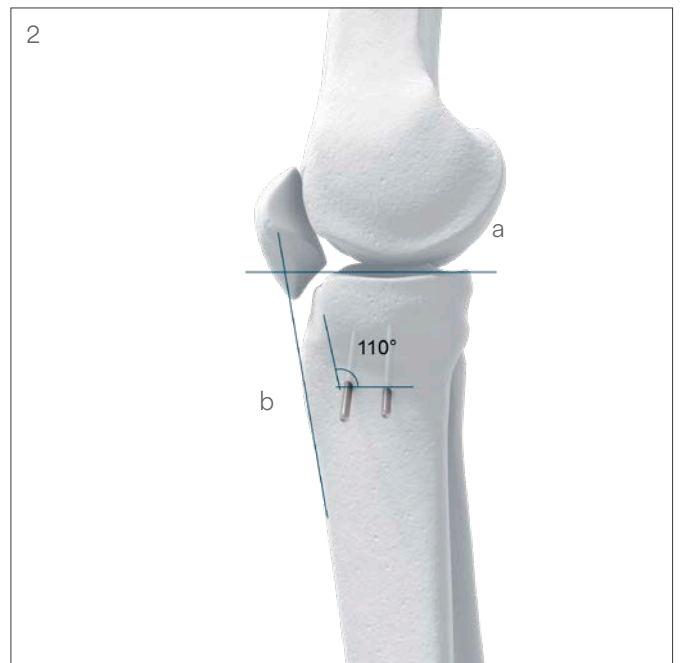
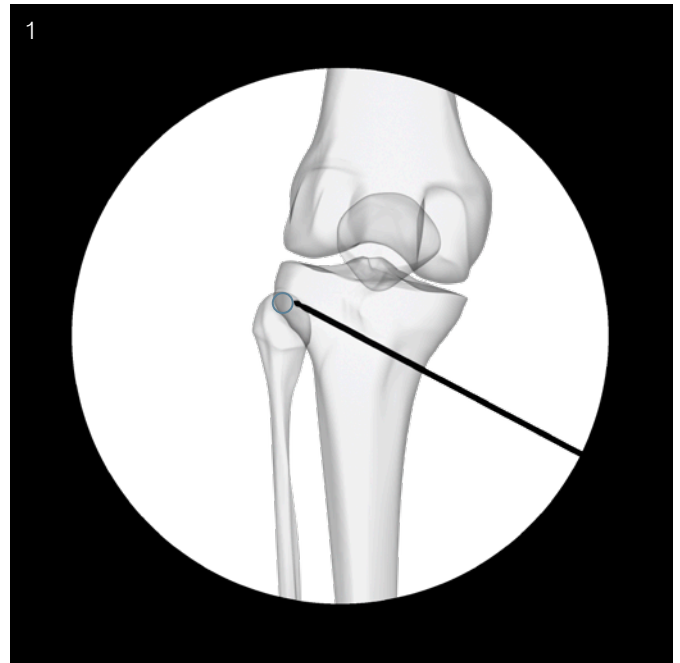

■ **Note:**

To determine the cutting depth, hold a third wire of the same length against the cortex and measure the excess length compared to the inserted wires. Generally the tibial diameter is 5–10 mm smaller anteriorly than posteriorly. Note the measured values. In general the cutting depth is 10 mm less than the measured width of the tibia. (3, 4)

Position the knee in 90° flexion again and mark the course of the anterior ascending osteotomy, which runs at an angle of around 110° to the transversal saw cut ending behind the patellar tendon. This tuberosity segment should be at least 15 mm wide.

Mark the cutting depth (determined in the previous step) on the saw blade.

Perform the transverse osteotomy with an oscillating saw below the two Kirschner wires that act as a guide. Pay attention to completing the osteotomy cut of the hard posterolateral and posteromedial tibial cortex. Protect the anatomical structures dorsal to the posterior tibial surface with a retractor. (5)





Perform the entire sawing procedure slowly, with very little pressure and under constant cooling of the saw blade by irrigation. When the planned depth is achieved in the posterior two thirds of the tibia, perform the anterior ascending saw cut with the narrow saw blade. The ascending cut is a complete osteotomy including the medial and lateral aspects of the anterior cortex. (6)

**▲ Precaution:**

Proceed cautiously around the neurovascular structures. Saw in a slow and controlled manner to prevent the blade from deviating into the back of the knee. Ensure the retractor always follows the osteotomy lines while cutting. In order to avoid potential heat necrosis during sawing procedure:

- Continuously irrigate while sawing
- Never use a blunt saw blade

**■ Note:**

For convenience the guide wires can be shortened to allow access to the osteotomy.

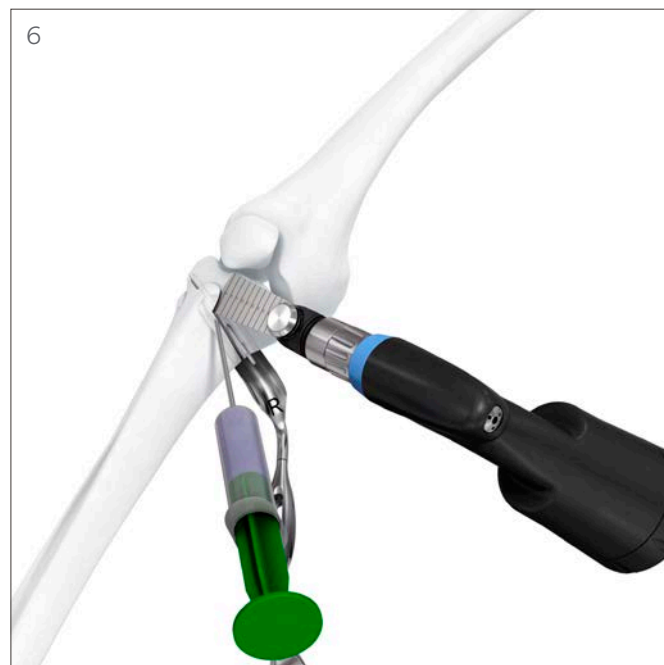

## 1b. Determine the position and conduct biplanar osteotomy with optional instruments

### Kirschner wires

02.111.903	Kirschner Wire Ø 2.0 mm with drill tip, length 150mm, Stainless Steel
292.210	Kirschner Wire Ø 2.0 mm with trocar tip, length 280 mm, Stainless Steel

### Instruments

395.161	TomoFix Aiming Arm
395.162	TomoFix Kirschner Wire Guide with Wing Nut
395.163	TomoFix Saw Guide, left or
395.164	TomoFix Saw Guide, right
395.165	TomoFix Angle Wing
395.166	TomoFix Retractor
519.108	Saw Blade 116/95×25×0.9/0.8 mm, for Oscillating Saw with AO/ASIF Coupling

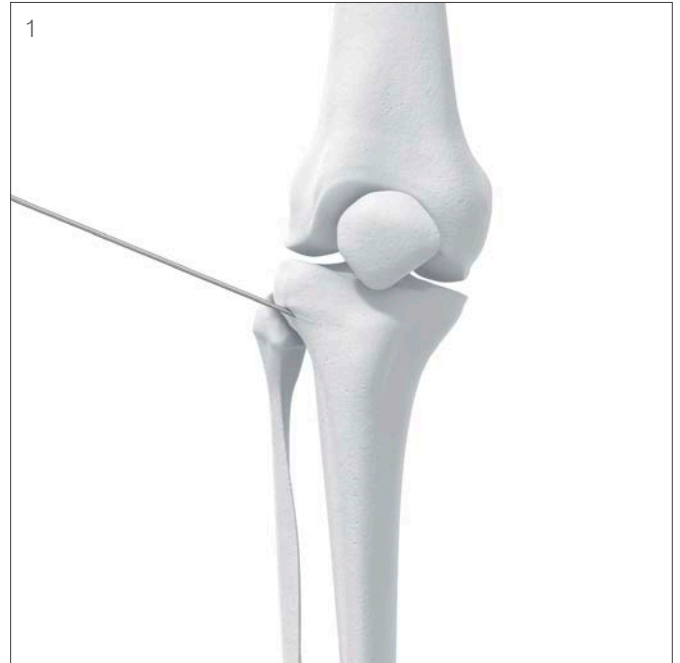

### Define the hinge point

Position the leg in full extension. Insert a Kirschner wire from the lateral side just above the fibular head (1).

The direction of the wire should follow the osteotomy line. Insert the Kirschner wire 2 cm into the bone. Verify the right position under image intensifier.

■ **Notes:**

- Use the head of the fibula as reference point for the entry of the lateral wire. Make sure that the entry point of the lateral wire is at least 10 mm below the tibia articular surface (2).
- In obese patients, it may be necessary to insert the first Kirschner wire more anteriorly to have more space between the guiding device and the anterior soft tissue later on.

Attach the wing nut onto the Kirschner wire guide by pressing the latch on the Kirschner wire guide (3a). Mount the Kirschner wire guide with wing nut on the toothed rack of aiming arm. (3b)

Slide the long bar with the slot over the lateral Kirschner wire. (4)

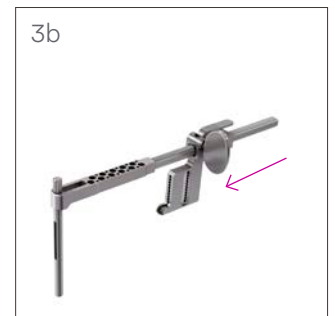
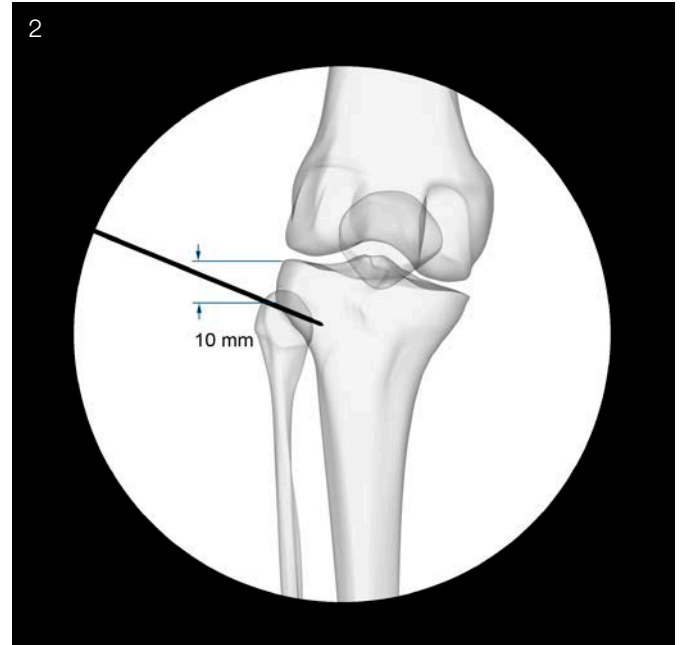

- ① Move the aiming arm until it follows the same direction as the osteotomy line. Ensure the round windows on the aiming arm appear as perfect circles under image intensification. (5)

Rotate the wing nut and provisionally tighten the aiming arm to the bone.

**Note:**

Do not tighten the aiming arm fully. It might change the position of the instrument.

To secure the position of the aiming arm, insert an AP Kirschner wire 2 cm into the small Kirschner wire holes provided on the aiming arm. (6) Fully lock the instrument by tightening the wing nut.

**Note:**

The Kirschner wires with trocar tip can be used for lateral and AP insertion.

Insert a reference Kirschner wire into a hole of Kirschner wire guide aiming to the cross point. This is a reference wire and does not need to be drilled into the medial cortex.

Drill in the first Kirschner wire in the second hole below the reference wire. (7)

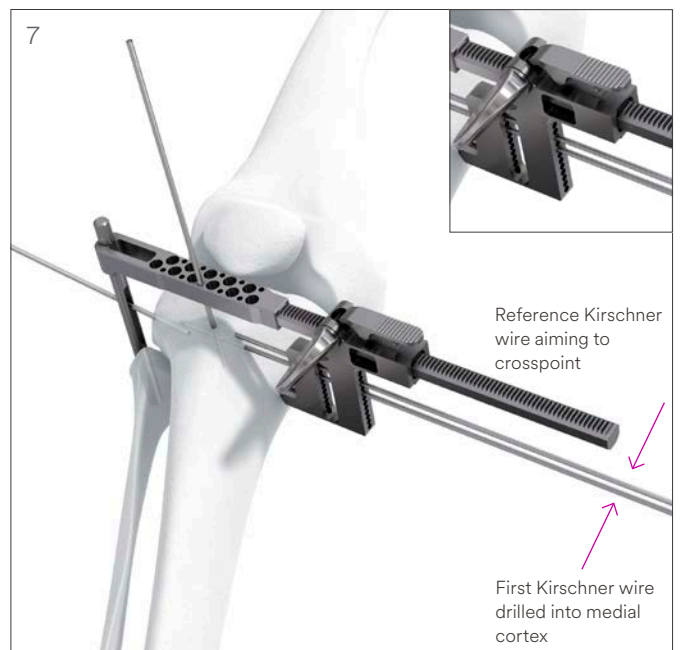
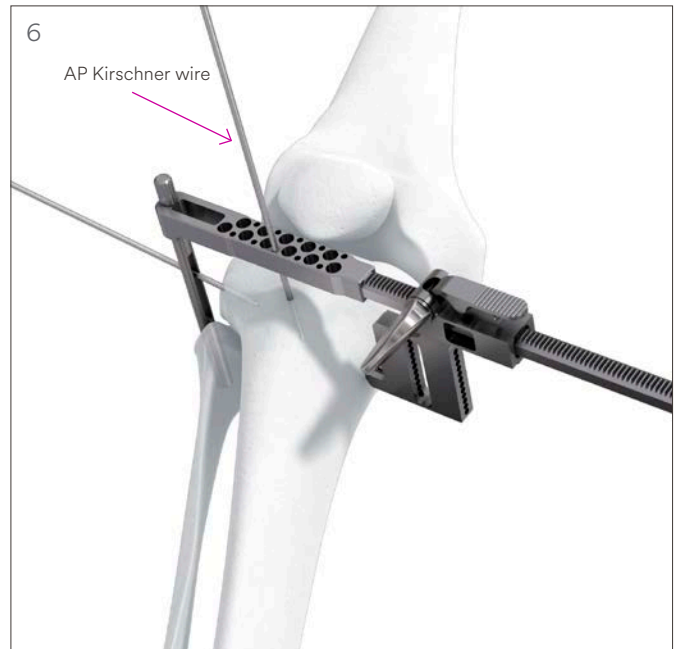
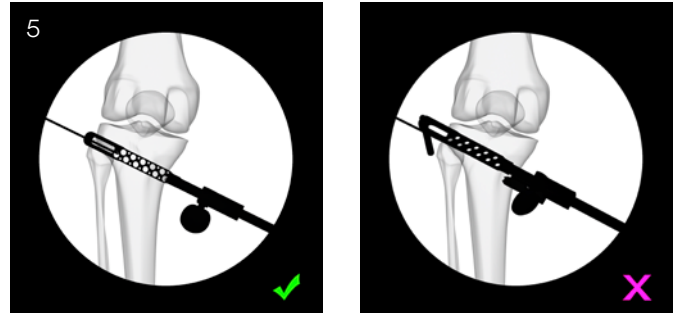

- ① The wire should end at the lateral tibial cortex. Under image intensification the depth of the Kirschner wire can be controlled. (8)

■ **Note:**

To drill in the first Kirschner wire easily, remove reference Kirschner wire after inserting the first Kirschner wire.

Disassemble the osteotomy guide by pressing the latch on the Kirschner wire guide and releasing the wing nut slightly. Remove the AP and lateral wires. Lastly remove the Osteotomy Guide leaving only the first Kirschner wire on the bone.

Insert a retractor below the tibia. (9)

■ **Note:**

In this step only one Kirschner wire is inserted.

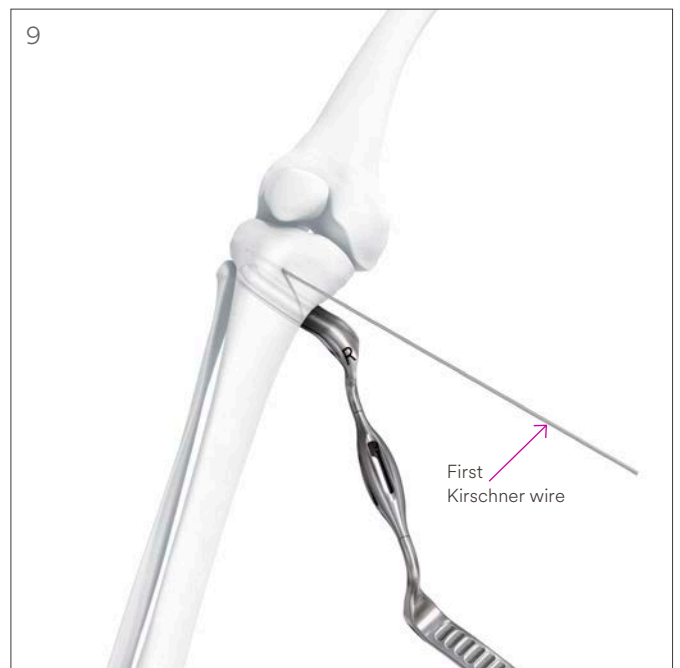
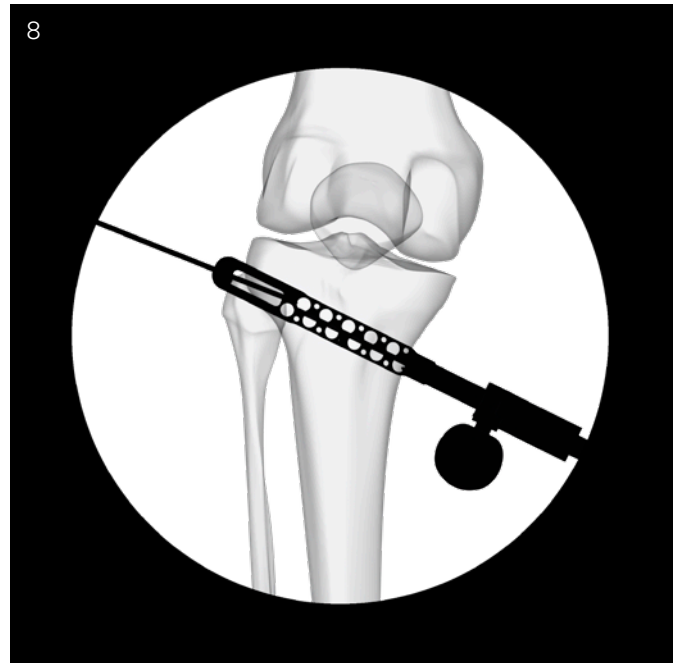

Slide the saw guide over the first Kirschner wire using the anterior hole of the saw guide. The marking L or R on the saw guide should be in the correct direction and facing you. Make sure the saw guide is positioned as close as possible to the bone.

■ **Note:**

Make sure to use the appropriate saw guide during this step. The guides are marked L and R accordingly, for the Left and Right tibia.

- ① Align the lateral tibia slope under AP projection with image intensification. Approximately 10° of knee flexion is required.

Insert the second Kirschner wire into the posterior hole of the saw guide. (10)

- ① To maintain the inclination of the tibial slope, the wires must overlap under image intensification showing one line. The second wire should also end at the lateral tibial cortex. (11)

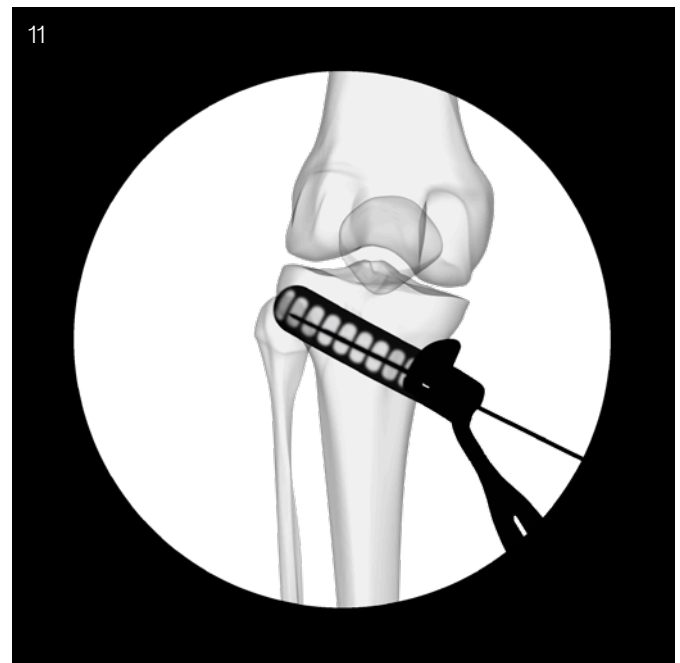
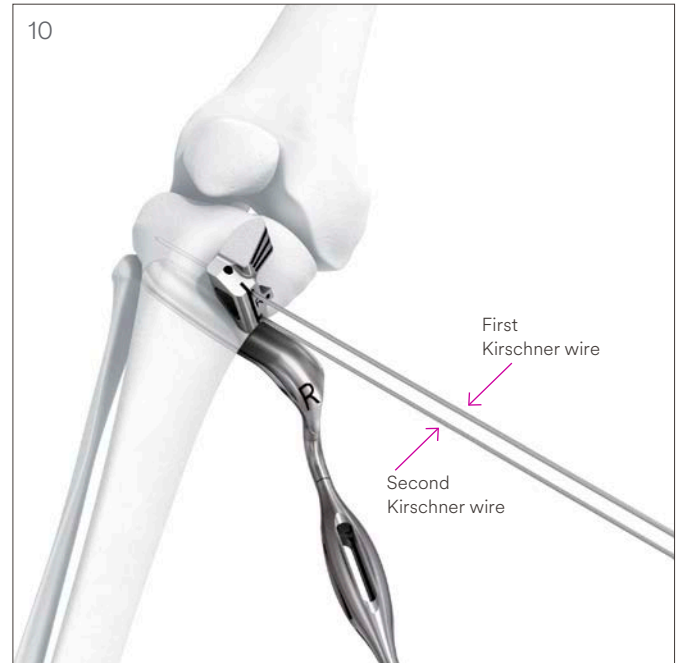

■ **Note:**

To determine the cutting depth, hold a third wire of the same length against the saw guide and measure the excess length compared to the inserted wires. (12)

To secure the saw guide, drill a Kirschner wire 2 cm into the fixation hole. Ensure that the fixation wire does not protrude through the posterior cortex (13).

■ **Notes:**

- If the saw guide moves during sawing, stabilize it by drilling the fixation Kirschner wire deeper.
- The Kirschner wires can be shortened to allow access to the osteotomy.

Mark the cutting depth (determined in the previous step) on the saw blade. Perform the transverse osteotomy with an oscillating saw through the transverse slot of the saw guide.



■ **Note:**

Stop sawing when the tip of the saw blade is 1cm away from the lateral hinge point. (14)

Be sure to complete the osteotomy cut of the hard posterolateral and posteromedial tibial cortex. Protect the anatomical structures dorsal to the posterior tibial surface with the radiolucent retractor.

Perform the entire sawing procedure slowly, with little pressure and under constant cooling of the saw blade by irrigation through the triangular opening at the bottom of the saw guide. (15)

▲ **Precaution:**

Proceed cautiously around the neurovascular structures. Saw in a slow and controlled manner to prevent the blade from deviating into the back of the knee. Ensure the retractor always follows the osteotomy lines while cutting. In order to avoid potential heat necrosis during sawing procedure:

- Continuously irrigate while sawing
- Never use a blunt saw blade

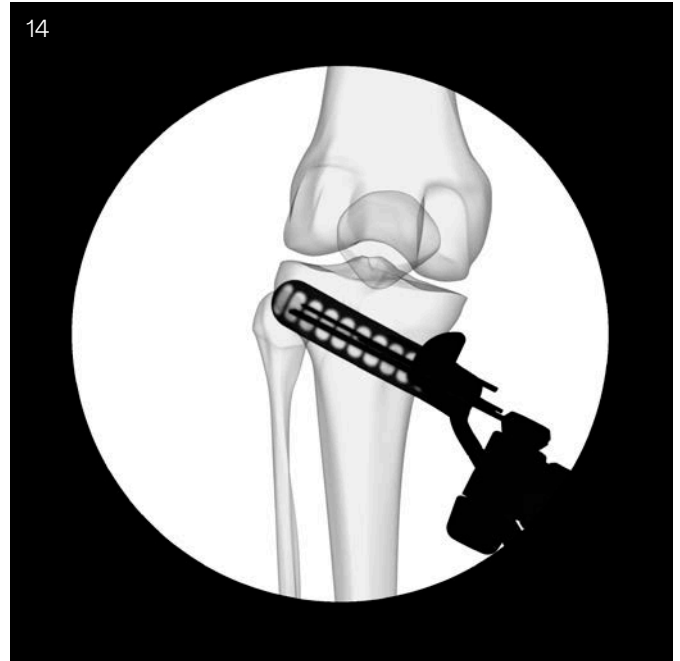



■ **Notes:**

- To ensure the posterolateral cortex is cut completely a ruler can be used to palpate the transverse cut. If the ruler hits the retractor the transverse cut has been completed. (16)
- To measure the depth of the saw blade the technique for measuring the length of the Kirschner wire should be used.

An angel wing is provided to help define the correct angle for the anterior ascending cut.

Insert the angel wing into the different ascending cut slots on the saw guide and define the angle for the ascending cut. The angulations of the slots are 100°, 110° and 120°. (17)

Perform the complete anterior ascending saw cut according to the defined angle.

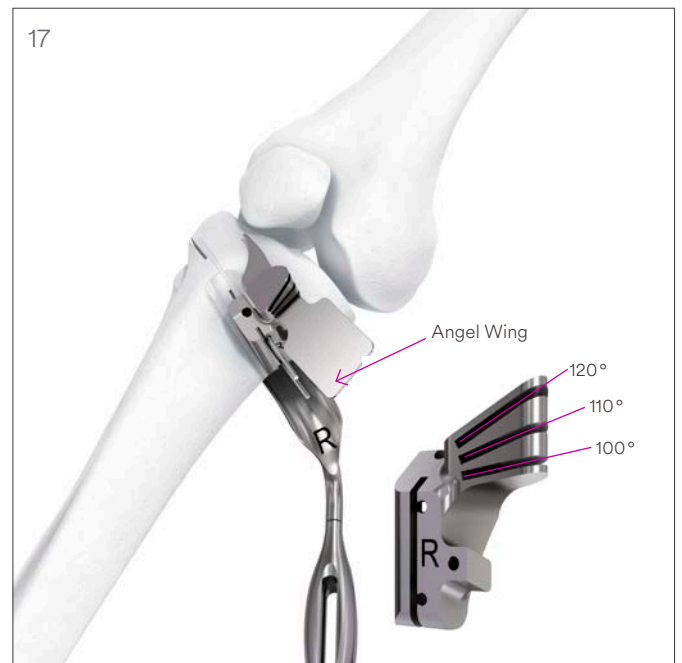
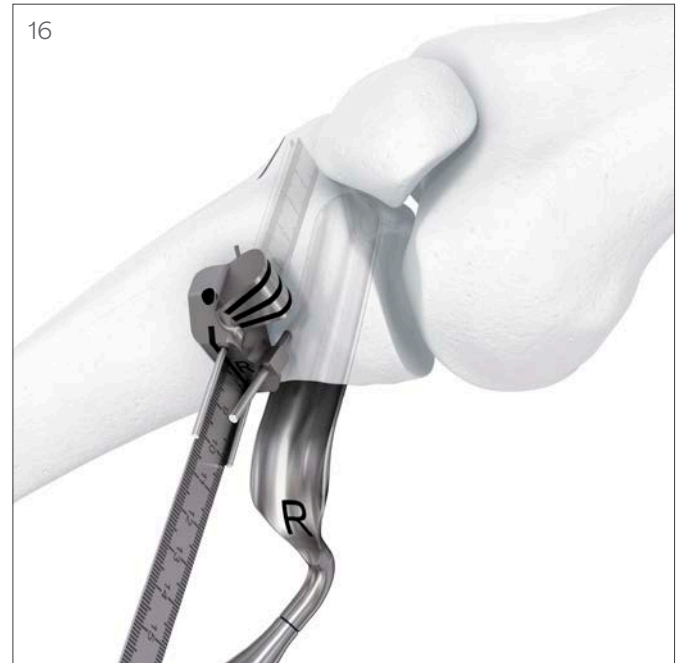

The ascending cut is a complete osteotomy including the medial and lateral aspects of the anterior cortex. (18)

When the osteotomy is completed, remove the Kirschner wire from the fixation hole and remove the saw guide.

■ **Notes:**

- A saw blade of proper width should be selected based on patient stature. The saw blade should not make contact with the distal femur.
- Depending on surgical preference the sequence of the transverse and ascending cuts can also be changed.

▲ **Precaution:**

Proceed cautiously around the neurovascular structures. Saw in a slow and controlled manner to prevent the blade from deviating into the back of the knee. Ensure the retractor always follows the osteotomy lines while cutting. In order to avoid potential heat necrosis during sawing procedure:

- Continuously irrigate while sawing
- Never use a blunt saw blade

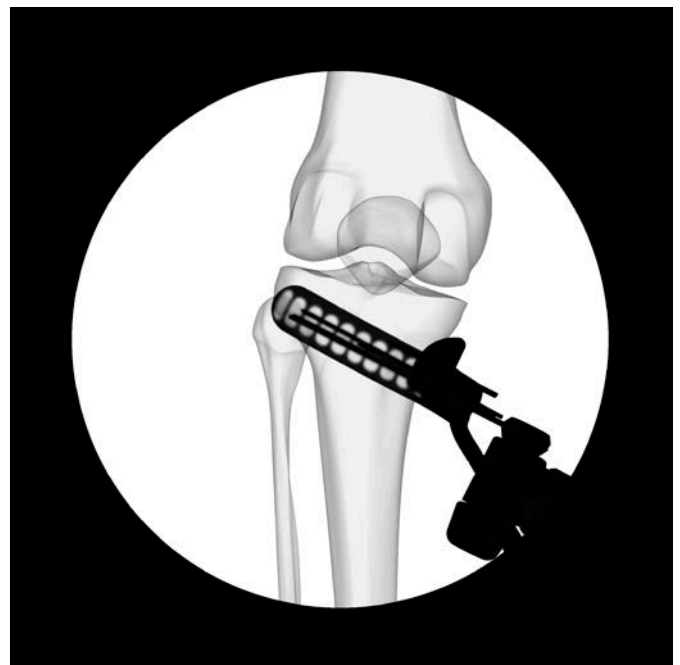

## 2. Open the osteotomy

### Instruments

397.992	TomoFix Osteotomy Chisel, width 10 mm
397.993	TomoFix Osteotomy Chisel, width 15 mm
397.994	TomoFix Osteotomy Chisel, width 20 mm
397.995	TomoFix Osteotomy Chisel, width 25 mm

Insert an osteotomy chisel into the transverse osteotomy up to the lateral bony hinge using light hammer blows. The insertion depth corresponds with the cutting depth. Mark the cutting depth on the first osteotomy chisel. Then slowly insert a second osteotomy chisel between the first chisel and the guide wires. Insert the chisel 10 mm less deep than the first one. (1)

### ■ Note:

Leave the two guide wires in place while opening and spreading the osteotomy. This will stiffen the proximal segment and may limit fracturing of the articular surface of the tibia. (2)

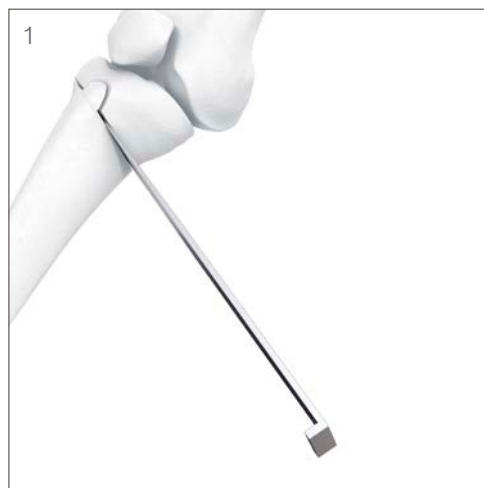

### 3. Spreading the osteotomy

#### General aspects

Open and spread the osteotomy slowly over a period of several minutes in order to prevent fracturing of the lateral cortex. Intra-articular secondary fractures can arise if the osteotomy is spread too quickly.

■ **Note:**

Due to the complexity of the medial collateral ligament (MCL), the osteotomy tends to open more anteriorly during spreading, thus increasing the caudal inclination of the tibial plateau. It is therefore important to ensure sufficient release of the long superficial fibers of the MCL. The opening of the osteotomy should be achieved by a spreader inserted as far posteromedial as possible. If needed, release more of the distal MCL to provide posterior opening of the osteotomy.

Choose from the following options:

#### 3a.

Spread the osteotomy with the chisel technique.

#### 3b.

Spread the osteotomy with a bone spreader.

### 3a. Spread the osteotomy with the chisel technique

#### Instruments

397.992	TomoFix Osteotomy Chisel, width 10 mm
397.993	TomoFix Osteotomy Chisel, width 15 mm
397.994	TomoFix Osteotomy Chisel, width 20 mm
397.995	TomoFix Osteotomy Chisel, width 25 mm
395.001	TomoFix Osteotomy Gap Measuring Device, Stainless Steel

Additional chisels may be inserted between the first two for gradual spreading of the osteotomy. Continue inserting a third, fourth and fifth chisel until the desired opening angle is reached. Insert each new chisel slightly less deep than its predecessor. (1, 2)

#### ■ Note:

Before removing the chisels, gently hammer one gap measuring device into the opened osteotomy gap until it grips the bone. (3)



---

### 3b. Spread the osteotomy with bone spreader

---

#### Instruments

---

399.100	Bone Spreader, speed lock, width 8 mm, length 210 mm
---------	---

---

As an alternative to spreading the osteotomy with chisels, the bone spreader may be used.

Use at least two chisels to gain an initial osteotomy gap as described in step 2. Insert the bone spreader in the dorsomedial intercortical portion of the osteotomy gap. Slowly spread the osteotomy by opening the bone spreader until the desired opening angle is reached (1).

■ **Note:**

Measure the opening and ensure that the height is accurate based on operative plan. If the height is measured intraoperatively it has to be calculated as height of opening plus thickness of the saw blade (0.9 mm).



## 4. Check the correction

### Instruments

03.108.030	Alignment Rod
03.108.031	Stand, large, for Alignment Rod, with handles
03.108.032	Stand, small, for Alignment Rod
399.100	Bone Spreader, speed lock, width 8 mm, length 210 mm
395.001	TomoFix Osteotomy Gap Measuring Device, Stainless Steel

### Optional instrument

324.060	Calliper for Corpectomy, short, Stainless Steel
---------	---



While spreading the osteotomy using the techniques described above in step 3, it is necessary to adjust it according to the preoperative plan. Constantly check the alignment of the leg and the height of the opening while spreading. For verification of the weight-bearing axis, put the leg in full extension. When the knee is extended, pay attention to the adaptation of the surfaces of the anterior ascending part of the osteotomy.

### ▲ Precaution:

- ❶ The control and the fine adjustment of the osteotomy must always occur with the leg in full extension. Always monitor the osteotomy with the image intensifier. Check the tibial slope for possible changes. Avoid malrotation and medial and lateral destabilization.

To measure the height of the osteotomy, use the gap measuring device which measures the opening height in millimeters in the posterior part of the osteotomy.

Hammer the gap measuring device into the opened osteotomy gap until it grips the bone. Slide the sledge towards the gap until it has reached the cortex. The opening value in millimeters can then be read from the scale. (1)

A second measuring device may be used to maintain the opening of the osteotomy after the instrument used for spreading has been removed. The gap measuring device should be positioned in the posteromedial aspect and the implant should be placed directly anterior in contact with the gap measuring device as far posterior as possible. (2)

■ **Note:**

Alternatively, the Caliper for Corpectomy (324.060) may be used to measure the osteotomy height.





The alignment rod is used to confirm correction of the mechanical axis of the leg and is used with an image intensifier. Attach handles to the large stand to hold the alignment rod in the correct position, without hand exposure to the x-ray beam. The handles may be connected to the stand perpendicular to the rod.

Place the alignment rod over the leg and align the metal rod at the center of the femoral head and at the center point of the ankle joint. (3) Use axial load by leaning against the foot to simulate body weight. Measure the height of opening and adjust it according to preoperative planning.

- Ⓒ Check it with an image intensifier. The axis can be adjusted by opening or closing the osteotomy as required. Adjust the weight-bearing line according to the preoperative plan. (4)

To check the knee joint line, a 2.0 mm Kirschner wire can be inserted into the stand at a right angle to the metal rod as reference during image intensification.

For further information on the alignment rod please refer to the handling technique.

**Note:**

Only a standing full leg x-ray will provide confirmation of the leg axis.

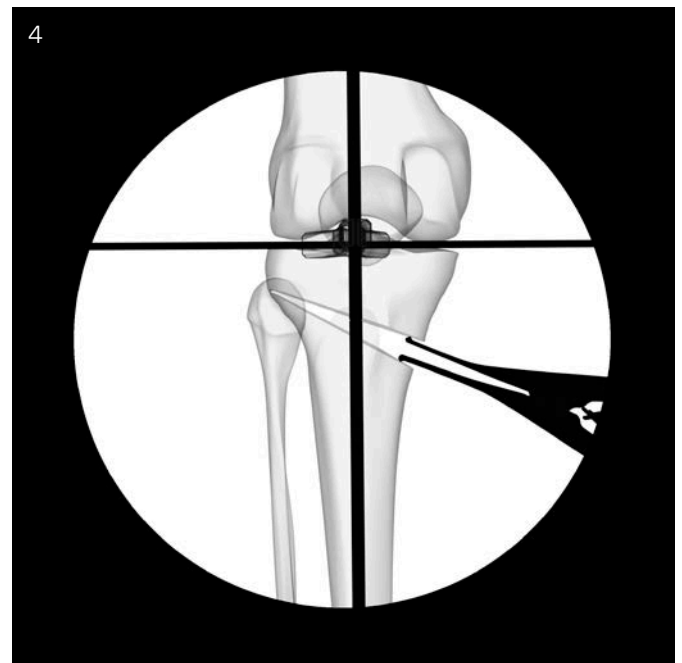
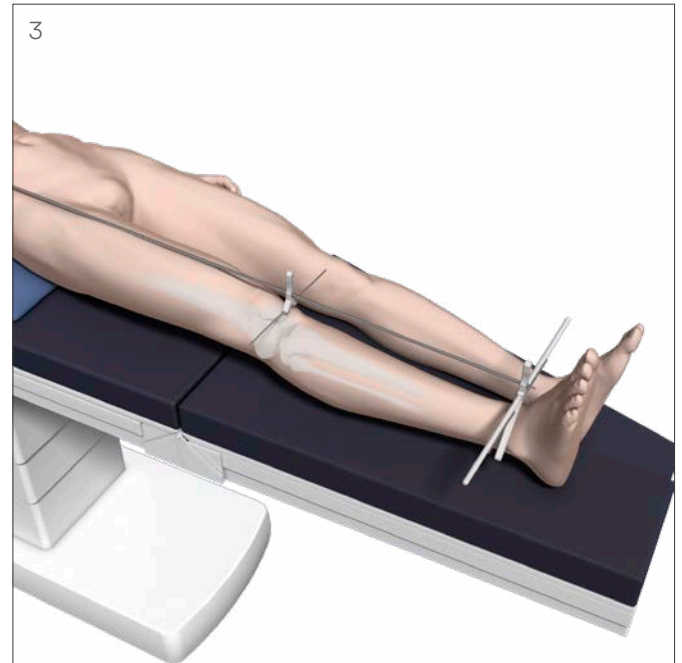

## Positioning and Fixation of the Plate

### 1. Insert the plate subcutaneously

#### Kirschner wire

292.210 Kirschner Wire Ø 2.0 mm with trocar tip, length 280 mm, Stainless Steel

#### Instruments

399.100 Bone Spreader, speed lock, width 8 mm, length 210 mm

323.042 LCP Drill Sleeve 5.0, for Drill Bits Ø 4.3 mm

413.309 LCP Spacer Ø 5.0 mm, length 2 mm, Titanium Alloy (TAN)

323.044 Centering Sleeve for Kirschner Wire Ø 2.0 mm, length 110 mm, for No. 323.042

395.001 TomoFix Osteotomy Gap Measuring Device, Stainless Steel

Use the bone spreader forceps or the gap measuring device to maintain the opening. (1)

Carefully remove the guide wires.

Insert the prepared plate subcutaneously on the medial side of the tibia plateau. The shaft portion must be aligned with the tibial diaphysis to avoid anterior or posterior cortical overhang.

Position the plate under the image intensifier so that the solid plate segment is bridging the osteotomy. Ensure that the proximal part of the plate head is parallel to the medial tibia slope. The proximal locking screws should be placed 1 cm subchondral to the joint line. (2)

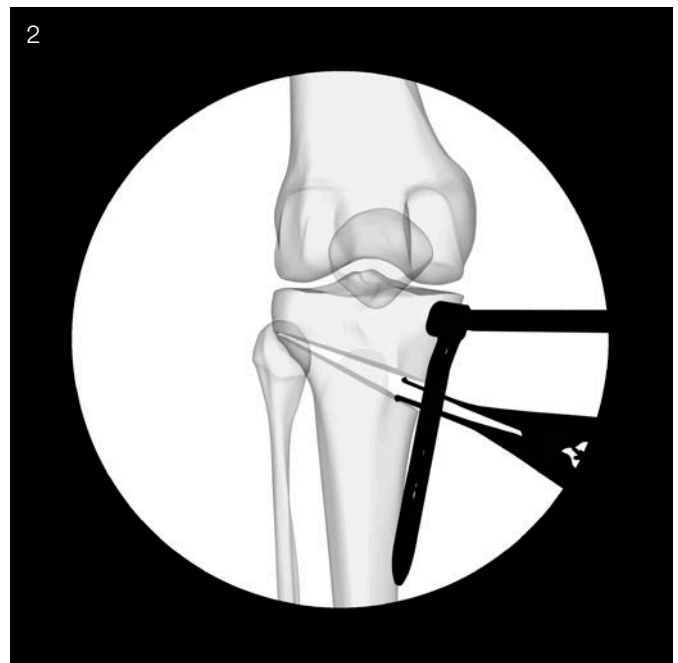

---

Temporarily secure the plate by insertion of a Kirschner wire into the central drill sleeve using a centering sleeve. (3)



## 2. Proximal fixation of the plate (holes A, B and C)

### Kirschner wire

292.210 Kirschner Wire Ø 2.0 mm with trocar tip, length 280 mm, Stainless Steel

### Instruments

310.430 LCP Drill Bit Ø 4.3 mm with Stop, length 221 mm, 2-flute, for Quick Coupling

323.500 LCP Universal Drill Guide 4.5/5.0

323.044 Centering Sleeve for Kirschner Wire Ø 2.0 mm, length 110 mm, for No. 323.042

324.052 Torque-limiting Screwdriver 3.5, self-holding, for Locking Screws Ø 5.0 mm

314.150 Screwdriver Shaft, hexagonal, large, Ø 3.5 mm

### Optional instruments

323.040 Depth Gauge with Stop for Screws Ø 5.0 mm, measuring range to 110 mm, for No. 323.042

Drill screw holes with the LCP drill bit Ø 4.3 mm and insert the three proximal self-tapping locking screws one after the other. (1)

Determine the screw lengths either by reading the drilled depth from the laser mark on the drill bit or with the TomoFix depth gauge through the drill sleeve (2). The chosen screws should be as long as possible without protruding the lateral cortical bone.

### ▲ Precaution:

In order to avoid potential damage to the neurovascular structures be sure not to rotate the plate when unscrewing the drill sleeves.



While firmly holding the TomoFix plate onto the tibia in its correct position, insert screws into holes A and C. Remove the Kirschner wire from hole B and replace it with a self-tapping locking screw. Insert the screws using a power tool, but do not fully tighten them. (3)

Finally, lock the screws manually with a screwdriver using the torque limiter (4). Recommended torque is reached after one click.

**▲ Precaution:**

To ensure sufficient tightening of locking head screws and to reduce the risk of cold welding of the screw head to the plate, locking head screws should always be tightened by hand using a torque limiter.



### 3. Insert lag screw

#### Instruments

310.290	Drill Bit $\varnothing$ 3.2 mm, length 195/170 mm, 2-flute, for Quick Coupling
323.500	LCP Universal Drill Guide 4.5/5.0
314.270	Screwdriver, hexagonal, large, $\varnothing$ 3.5 mm, with Groove, length 245 mm
319.100	Depth Gauge for Screws $\varnothing$ 4.5 to 6.5 mm, measuring range up to 110 mm

Insert a temporary lag screw in a neutral position of the dynamic part of the LCP hole 1 (1, 2). Use the LCP universal drill guide to drill a hole angulated slightly distally and anteriorly so it will not interfere with a locking screw which will later be inserted into the locking position of this hole. Determine the required screw length with the depth gauge. (3)

#### ■ Note:

For the closed wedge surgical technique, insert a temporary lag screw in a compression position of the dynamic part of the LCP hole 1.

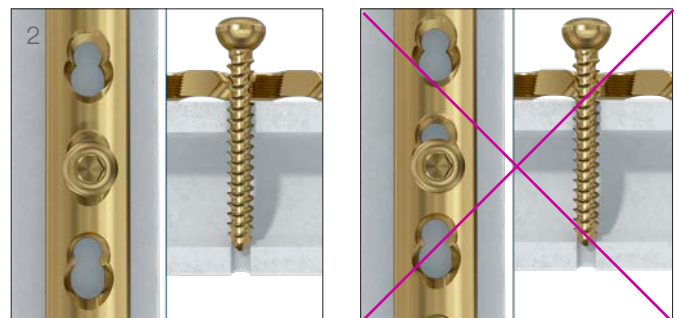

It is mandatory to place the leg in full extension at this stage of the operation. Use a hard bolster under the heel and manual stress to achieve full extension before the lag screw is tightened.

**▲ Precautions:**

- Monitor potential correction loss and the ventral bone contact of the ascending osteotomy. Check the bone axis and, if necessary, make final corrections. Avoid compressing soft tissue. (4)
- The cortical screw must be angulated slightly distal, to avoid the trajectory of the bicortical locking screw in the same hole, which is required in the following steps. (5)

Insert a self-tapping cortical screw using a power tool, but do not fully tighten it. (6)

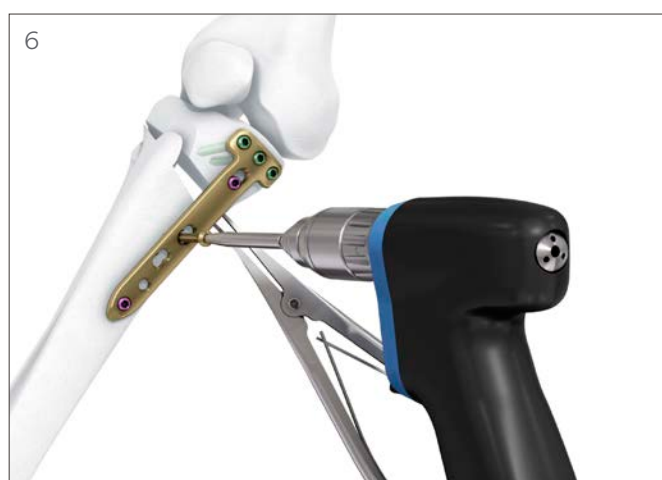
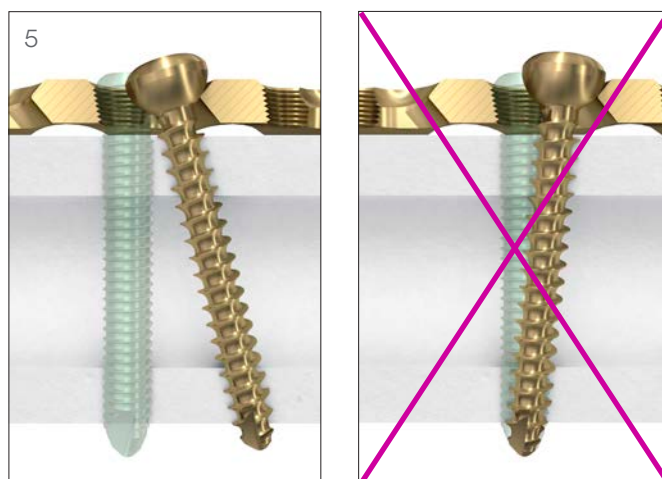

Finally, tighten the screw manually with a screwdriver. (7, 8)

■ **Note:**

Exert special care when tightening the cortex screw to avoid thread stripping and associated damage to the bone.

This lag screw compresses the lateral hinge by pulling the distal osteotomy segment towards the plate and forcing the plate into suspension which will impose pressure upon the lateral hinge. Potential fissures within the lateral bone hinge are brought under elastic preload and distraction on the lateral side is eliminated. Watch the osteotomy gap constantly while the lag screw is slowly tightened to avoid secondary loss of correction. (9)





---

## Compression of the lateral hinge

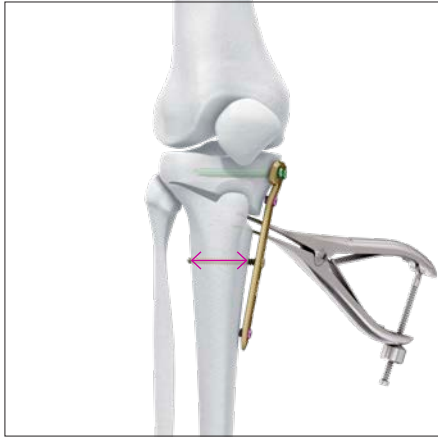

A lag screw pulls the distal osteotomy segment towards the plate...



...and forces the plate into suspension, creating an elastic preload...



...which imposes pressure upon the lateral hinge.

### ■ Note:

To see the effect of the lag screw, insert the drill sleeve in hole 3 before compressing.

## 4. Distal fixation of the plate

### Instruments

310.430	LCP Drill Bit $\varnothing$ 4.3 mm with Stop, length 221mm, 2-flute, for Quick Coupling
323.042	LCP Drill Sleeve 5.0, for Drill Bits $\varnothing$ 4.3 mm
324.052	Torque-limiting Screwdriver 3.5, self-holding, for Locking Screws $\varnothing$ 5.0 mm
314.150	Screwdriver Shaft, hexagonal, large, $\varnothing$ 3.5 mm

Make a stab incision over hole 3. The incision will be used to gain access to holes 2, 3, and 4. The position of hole 3 is approximately 6.5 cm below hole D.

Drill a unicortical hole with the LCP drill sleeve through the locking portion of hole 2. (1)

Insert a unicortical self-tapping locking screw using a power tool, but do not fully tighten it. (2)

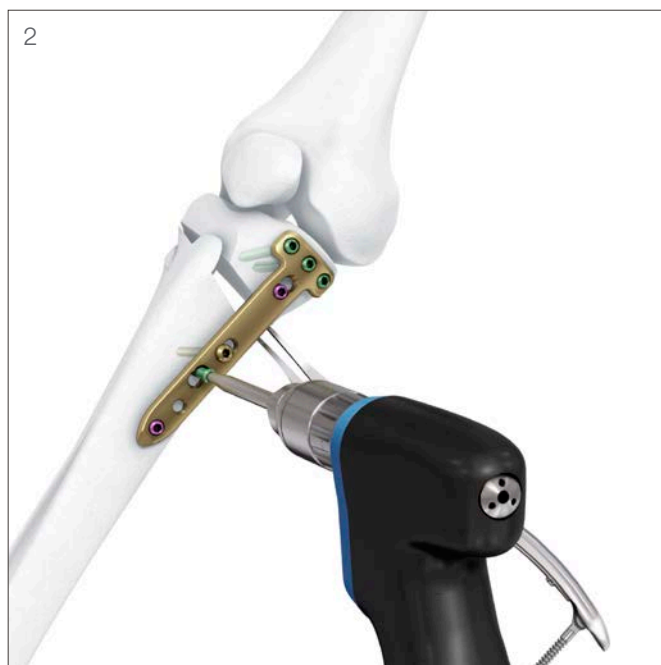

Finally lock the screw manually with a screwdriver using the torque limiter (3). Recommended torque is reached after one click.

Repeat these actions for hole 3.

**▲ Precautions:**

- To ensure sufficient tightening of locking head screws and to reduce the risk of cold welding of the screw head to the plate, locking head screws should always be tightened by hand using a torque limiter.
- When inserting bicortical locking screws instead of unicortical screws into hole 3 and 4 of TomoFix Medial High Tibial Plate, attention needs to be paid so that the drill tip and the screws will not disrupt the deep peroneal nerve.

**■ Note:**

For stability purposes, bicortical self-tapping screws may be used in the three distal holes, using the same technique as described above.



## 5. Replace the distal LCP spacer with a locking head screw

### Instruments

310.430	LCP Drill Bit Ø 4.3 mm with Stop, length 221 mm, 2-flute, for Quick Coupling
323.042	LCP Drill Sleeve 5.0, for Drill Bits Ø 4.3 mm
324.052	Torque-limiting Screwdriver 3.5, self-holding, for Locking Screws Ø 5.0 mm
314.150	Screwdriver Shaft, hexagonal, large, Ø 3.5 mm
314.270	Screwdriver, hexagonal, large, Ø 3.5 mm, with Groove, length 245 mm

Remove LCP spacer Ø 5.0 mm from hole 4. (1)

Drill a unicortical hole with the LCP drill sleeve through the locking portion of hole 4. (2)

Insert a unicortical self-tapping locking screw using a power tool, but do not fully tighten it. (3)



---

Finally, lock the screw manually with a screwdriver using the torque limiter. (4)

Recommended torque is reached after one click.

**▲ Precaution:**

To ensure sufficient tightening of locking head screws and to reduce the risk of cold welding of the screw head to the plate, locking head screws should always be tightened by hand using a torque limiter.



## 6. Replace lag screw with a locking head screw

### Instruments

310.430	LCP Drill Bit $\varnothing$ 4.3 mm with Stop, length 221 mm, 2-flute, for Quick Coupling
323.042	LCP Drill Sleeve 5.0, for Drill Bits $\varnothing$ 4.3 mm
324.052	Torque-limiting Screwdriver 3.5, self-holding, for Locking Screws $\varnothing$ 5.0 mm
314.150	Screwdriver Shaft, hexagonal, large, $\varnothing$ 3.5 mm

### Optional instruments

323.040	Depth Gauge with Stop for Screws $\varnothing$ 5.0 mm, measuring range to 110 mm, for No. 323.042
---------	---

Remove the previously inserted lag screw from hole 1. (1)

#### ■ Note:

Since the following screw is placed bicortically, 2 mm needs to be added to the measurement result.

Screw the LCP drill sleeve into plate hole 1 and drill a bicortical hole with the LCP drill bit  $\varnothing$  4.3 mm. (2)

Determine the screw length either by reading the drilled depth from the laser mark on the drill bit or with the TomoFix depth gauge through the drill sleeve. Ensure that the hook grips on the far cortex edge.

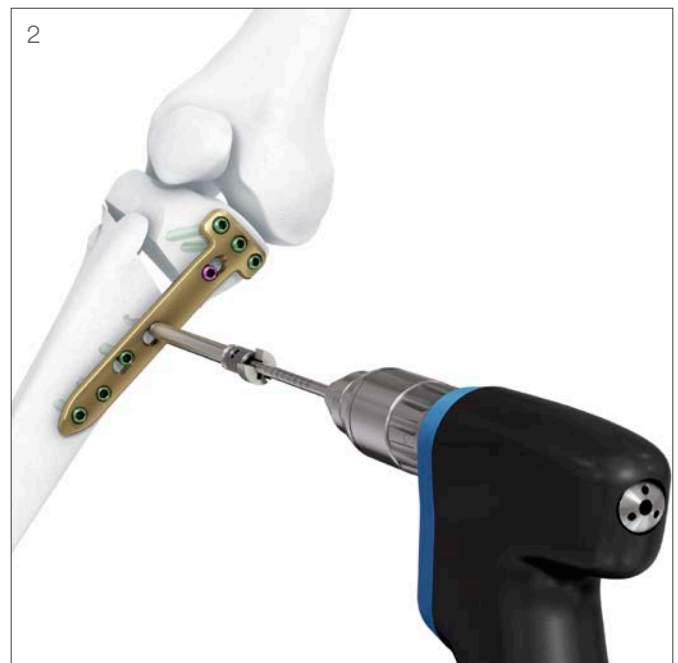

Remove the drill sleeve from the plate and insert a self-tapping bicortical locking screw. Insert the screw using a power tool, but do not fully tighten it. (3)

Finally, lock the screw manually with a screwdriver using the torque limiter. Recommended torque is reached after one click. (4)

**▲ Precaution:**

To ensure sufficient tightening of locking head screws and to reduce the risk of cold welding of the screw head to the plate, locking head screws should always be tightened by hand using a torque limiter.



## 7. Replace the proximal LCP spacer with a locking head Screw

### Instruments

310.430	LCP Drill Bit $\varnothing$ 4.3 mm with Stop, length 221 mm, 2-flute, for Quick Coupling
323.042	LCP Drill Sleeve 5.0, for Drill Bits $\varnothing$ 4.3 mm
324.052	Torque-limiting Screwdriver 3.5, self-holding, for Locking Screws $\varnothing$ 5.0 mm
314.150	Screwdriver Shaft, hexagonal, large, $\varnothing$ 3.5 mm
314.270	Screwdriver, hexagonal, large, $\varnothing$ 3.5 mm, with Groove, length 245 mm

### Optional instruments

323.040	Depth Gauge with Stop for Screws $\varnothing$ 5.0 mm, measuring range to 110 mm, for No. 323.042
---------	---

Remove LCP spacer  $\varnothing$  5.0 mm. (1)

Screw the LCP drill sleeve into plate hole D and drill a screw hole with the LCP drill bit  $\varnothing$  4.3 mm. Ensure that the drill does not interfere with the screws placed in holes A, B or C and does not protrude through the lateral cortical bone. Determine the screw lengths either by reading the drilled depth from the laser mark on the drill bit or with the TomoFix depth gauge through the drill sleeve. (2)

Remove the drill sleeve from the plate. Insert a self-tapping locking screw using a power tool, but do not fully tighten it.

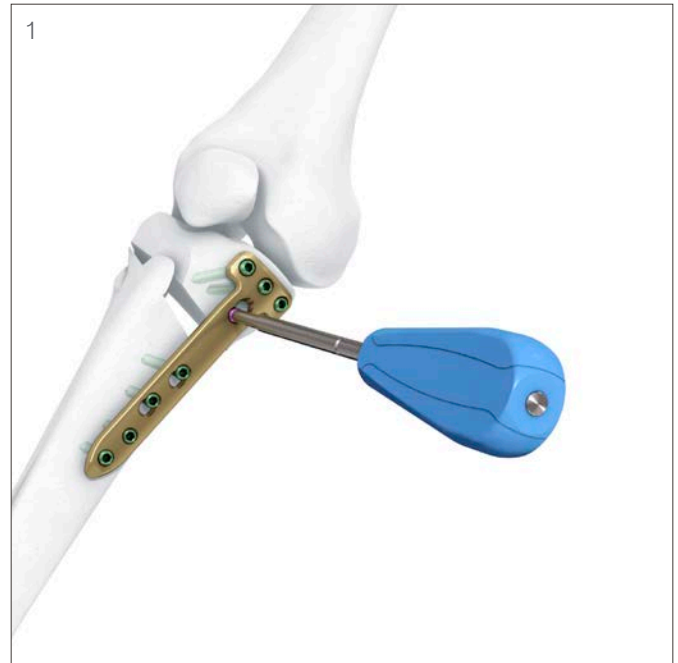



---

Finally, lock the screw manually with a screwdriver using the torque limiter. (3) Recommended torque is reached after one click.

**▲ Precaution:**

To ensure sufficient tightening of locking head screws and to reduce the risk of cold welding of the screw head to the plate, locking head screws should always be tightened by hand using a torque limiter.



## 8. Radiological control

- Check the result of the correction and the position of the implant using the image intensifier in two planes.

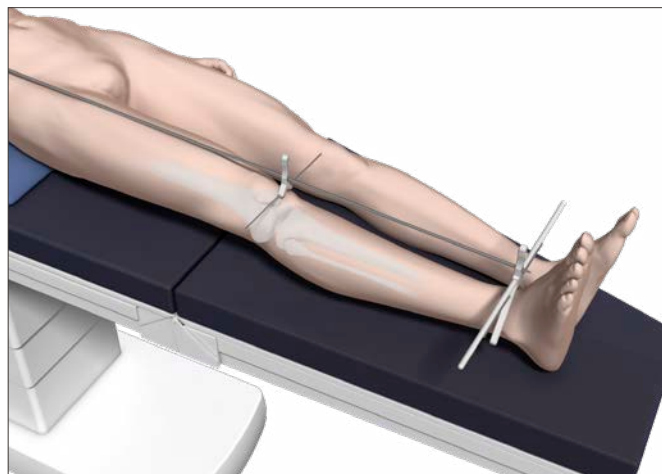
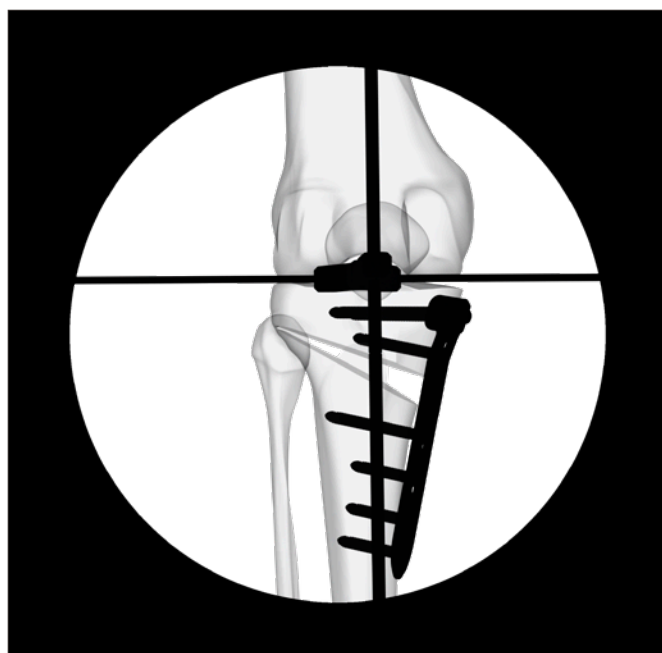

---

## 9. Wound closure

Fill the osteotomy site with blood clots. These clots must not be aspirated nor should the osteotomy be flushed empty. Close the subcutaneous layer with interrupted, thin resorbable sutures. Then close the skin with staples or interrupted sutures. Apply a padded elastic compression drape over the entire leg and place a cryo-compression unit over the knee.

### ■ Note:

Close the wound following general surgical guidelines. The technique described above is one possible approach and may differ from other standards.

## Postoperative Treatment and Implant Removal

---

### Postoperative treatment

Perform active and passive physiotherapy, manual lymph drainage, and electrical muscle stimulation if necessary. Preventive measures should be taken against thrombosis until full weight bearing is possible. Take follow-up x-rays in two planes.

#### ■ Note:

Define the postoperative treatment following general protocols. The technique described above is one possible approach and may differ from other standards.

### Implant removal

The TomoFix Plate does not generally need to be removed. However, if removal is desired, it should not be removed earlier than complete bone healing of the osteotomy, i.e., usually  $\geq 12$  months after surgery.

To remove the plate, unlock all screws from the plate, then remove the screws completely from the bone. This prevents simultaneous rotation of the plate when unlocking the last locking screw.

For details regarding implant removal refer to the “Screw Extraction Set” surgical technique guide.

# Closed Wedge Surgical Technique

## Preparation

### 1. Preoperative Planning

A preoperative plan should be completed for a correction osteotomy in order to determine the size of the bone wedge basis that will need to be removed in a closed wedge osteotomy.

A precise preoperative plan is crucial to the success of this procedure. The recommended method for planning is that of Miniaci. It must be done on the basis of the full weight-bearing long leg x-ray in AP view, either on paper or at a digital workstation. (1)

- Determine the mechanical axis of the leg: Draw a straight line from the center of the femoral head to the center of the ankle joint.
- Draw the new weight-bearing line from the center of the femoral head, passing the joint line through the desired position.
- Determine a hinge point (h). Generally the hinge point should be chosen on the lateral cortex and at the upper 1/3 proximal fibular head. (2)

#### ■ Note:

The optimal position of the hinge point may vary according to patient specific anatomy. Rotate the leg 30° internally to identify the optimal hinge point. The lateral hinge point should be within the proximal 1/3 of the fibular head.

- Connect the hinge point (h) with the center of the ankle joint (a). Rotate the connecting line h-a like a circle until it crosses the new weight bearing line. Connect the crossing point (b) with the hinge point h. The angle between the connecting line h-a and h-b is the angle of closing ( $\alpha$ ). Transfer the closing angle ( $\alpha$ ) to the level of the planned osteotomy. The height at the medial cortex (o) is the height of closing wedge.

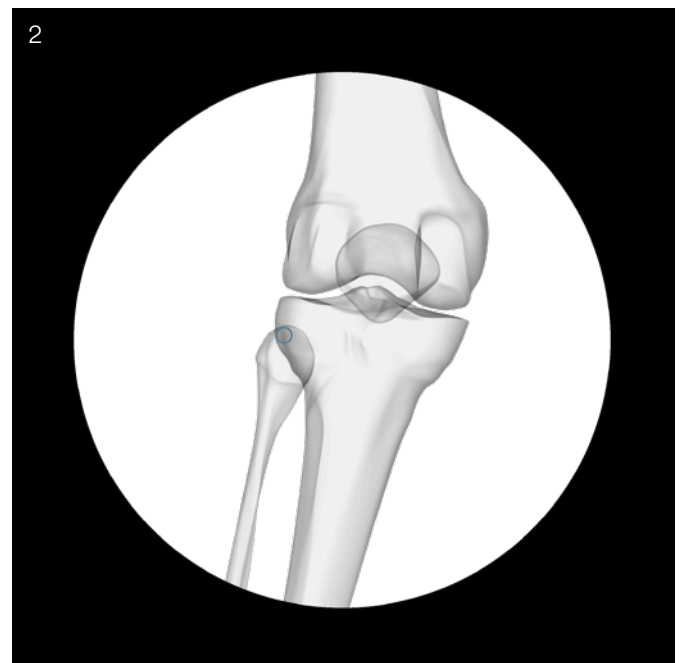
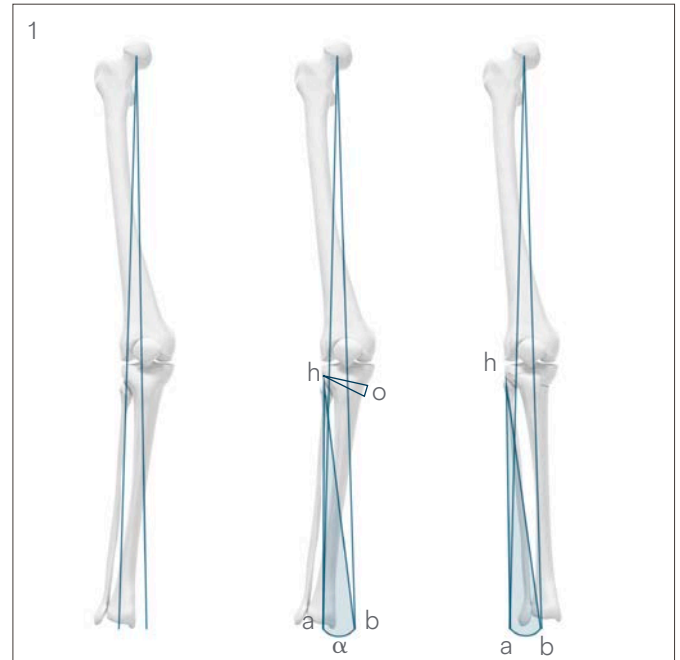

## Setting angle chart

The below chart determines the correction angle (°).  
This value is dependent on the osteotomy depth C (mm)  
and wedge basis B (mm).

### Example:

Osteotomy Depth 60 mm (C = 60 mm)  
Wedge basis 12 mm (B = 12 mm)  
Correction angle would be 12°

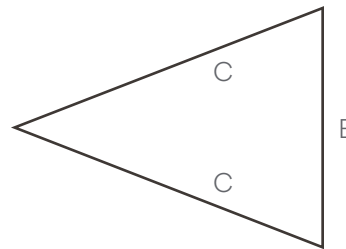

		Correction Angle															
		4°	5°	6°	7°	8°	9°	10°	11°	12°	13°	14°	15°	16°	17°	18°	19°
Mediolateral diameter of the osteotomy (mm)	50 mm	3	4	5	6	7	8	9	10	10	11	12	13	14	15	16	16
	55 mm	4	5	6	7	8	9	10	10	11	12	13	14	15	16	17	18
	60 mm	4	5	6	7	8	9	10	11	12	14	15	16	17	18	19	20
	65 mm	5	6	7	8	9	10	11	12	14	15	16	17	18	19	20	21
	70 mm	5	6	7	8	10	11	12	13	15	16	17	18	20	21	22	23
	75 mm	5	6	8	9	10	12	13	14	16	17	18	20	21	22	24	25
	80 mm	6	7	8	10	11	13	14	15	17	18	19	21	22	24	25	26

### ■ Note:

These instructions alone do not replace in-depth training  
in planning for osteotomies. It only serves as a general  
guideline.

## 2. Determine the position of the osteotomy

Determine the correction angle on the basis of the preoperatively calculated bone wedge basis B and the previously calculated osteotomy depth C with the aid of the setting angle chart.

Define the level of the proximal osteotomy under fluoroscopy with a 2.5 mm Kirschner wire. The osteotomy should start medial proximal and ascend lateral to the lateral hinge. The inserted depth of the Kirschner wire must correlate with the preoperative planned osteotomy depth C.

### ■ Note:

Use the head of the fibula as reference point for the hinge point. Make sure that the final position of the medial wire ends at least 5 mm below the tibia articular surface. (1)

- 1 Align the lateral tibia slope under AP projection in image intensification. Usually a flexion in the knee of approximately  $10^\circ$  is required. Place the second Kirschner wire about 2 cm anterior and parallel to the first wire. Make sure the insertion length of both wires are the same.
- 2 To maintain the inclination of the tibial slope, the wires must overlap under image intensification showing one line. The second wire should also end at the lateral tibial cortex.

To ensure the cutting depth is as preplanned osteotomy depth, hold a reference Kirschner wire of the same length against the bone and measure the excess length compared to the inserted wires. (2)

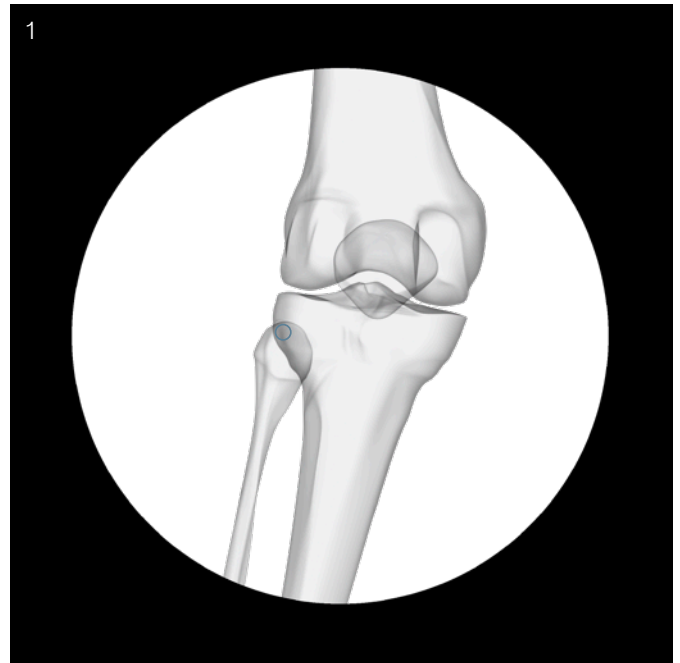

Calculate the height of basis according to preoperative plan and the depth of first two Kirschner wires. Insert the third Kirschner wire with the planned distance of height of basis, aiming to the hinge point.

- ① Check again the slope of medial tibia plateau under AP projection in image intensification. Place the fourth Kirschner wire about 2 cm anterior and parallel to the third wire. Make sure the insertion length of both wires are the same. (3)

- ① To maintain the inclination of the tibial slope, the wires must overlap under image intensification showing one line. The third and fourth wire should also end at the lateral tibial cortex.

■ **Note:**

For convenience the guide wires can be shortened to allow access to the osteotomy.

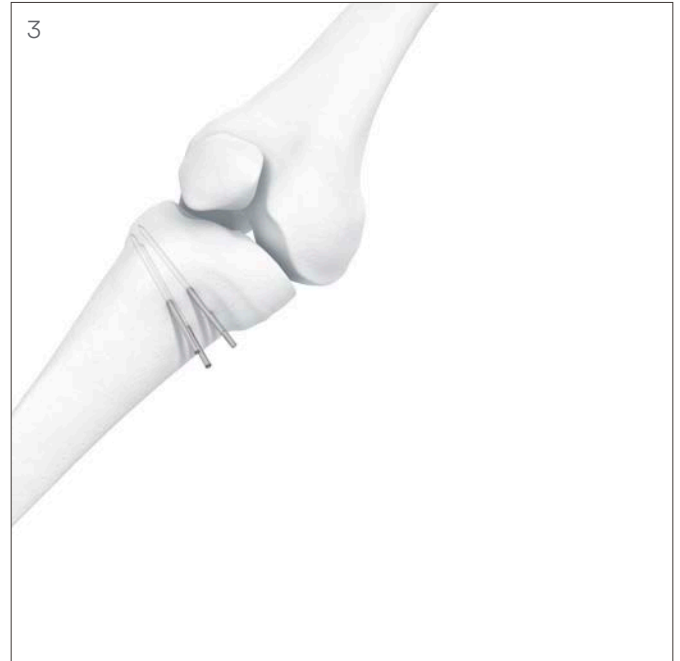



## Osteotomy

### Instruments

519.108	Saw Blade 116/95_25_0.9/0.8 mm, for Oscillating Saw with AO/ASIF Coupling
---------	---

Insert a retractor behind the tibia.

Mark the cutting depth (determined in the previous step) on the saw blade. Perform the two transverse osteotomies with an oscillating saw. (1)

Pay attention to completing the osteotomy cut of the hard posterolateral and posteromedial tibial cortex. Protect the anatomical structures dorsal to the posterior tibial surface with the retractor.

Perform the entire sawing procedure slowly, with very little pressure and under constant cooling of the saw blade by irrigation.

#### ▲ Precaution:

Proceed cautiously around the neurovascular structures. Saw in a slow and controlled manner to prevent the blade from deviating into the back of the knee. Ensure the retractor always follows the osteotomy lines while cutting. In order to avoid potential heat necrosis during sawing procedure:

- Continuously irrigate while sawing
- Never use a blunt saw blade

#### ■ Notes:

- To ensure the posterolateral cortex is cut completely a ruler can be palpated in the transverse cut. If the ruler hits the retractor the transverse cut has been successful.
- To measure the depth of the saw blade the technique for measuring the length of the Kirschner wire should be used.

Perform an anteriorly ascending cut with the oscillating saw. The ascending cut is a complete osteotomy including the medial and lateral aspects of the anterior cortex. (2)

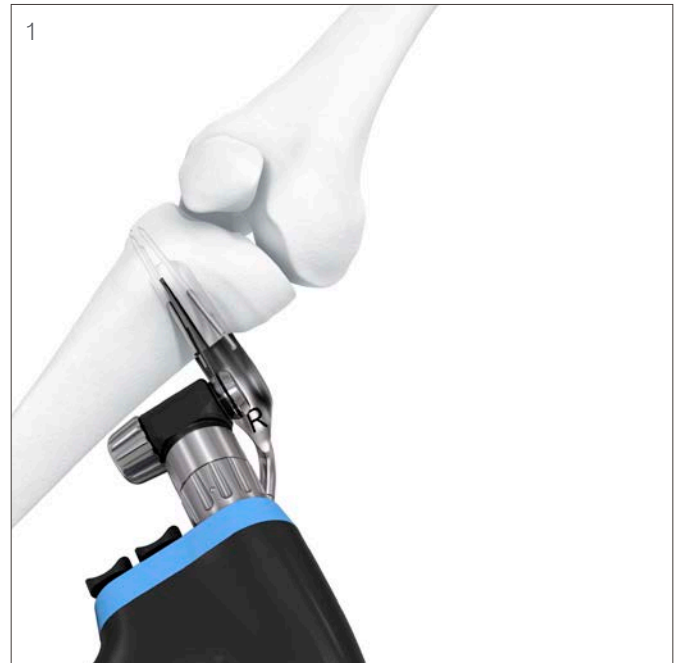

Remove the posterior bone wedge basis and close the osteotomy slowly to avoid lateral hinge breakage. (3, 4)

■ **Note:**

For fixation of the plate on closed wedge, the osteotomy gap can be compressed by eccentrically applying a self-tapping 4.5 mm cortex screw distal to the osteotomy in the dynamic part of combination hole 1. The screw should be inserted perpendicular to the plate surface.

For more information on approach, positioning and fixation of the plate, postoperative treatment and implant removal please refer to the open wedge surgical technique.



# Plates

---

The TomoFix Medial High Tibial Plate is based on the principles of the Locking Compression Plate (LCP). For positioning the plate is available in three sizes: standard, small, and anatomical. The plates are made of commercially pure titanium. In the proximal section of each plate there are 4 threaded holes. For TomoFix standard and small plates, there are 2 combination and 2 locking holes in the distal section. For TomoFix anatomical, there are 1 combination and 3 locking holes in the distal section for anchoring of the screws in the tibial shaft.

Choose either the standard, small or the anatomical plate based on the patient's anatomy, body weight, post-operative weight bearing schedule, and compliance. Also take the size of the osteotomy and the final stability of the construct into consideration.

**■ Note:**

The small version of the TomoFix Medial High Tibial Plate does not reach the same degree of stability as the standard plate.

The anatomical version of TomoFix Medial High Tibial Plate is available in a left and right version.

---

440.831S	TomoFix Tibial Head Plate, small, medial, proximal, shaft 4 holes, head 4 holes, length 112 mm, Commercially Pure Titanium, sterile
440.834S	TomoFix Tibial Head Plate, medial, proximal, 4 holes, Commercially Pure Titanium, sterile
440.837S	TomoFix Tibial Head Plate, anatomical, medial, proximal, left, head 4 holes, length 112 mm, Commercially Pure Titanium, sterile
440.838S	TomoFix Tibial Head Plate, anatomical, medial, proximal, right, head 4 holes, length 112 mm, Commercially Pure Titanium, sterile

---

TomoFix Plates are available nonsterile and sterile packed.  
For nonsterile implants, remove suffix S from article number.

Plate Dimensions	440.834S TomoFix (Standard)	440.831S TomoFix (Small)	440.837S, 440.838S TomoFix (Anatomical)
Length (L)	115 mm	112 mm	112 mm
Width (W)	16 mm	14 mm	14 mm
Thickness (T)	3 mm	3.2 mm	3.2 mm
Distance proximal holes A, B, C (P)	11 mm	9 mm	9 mm
Radius proximal part (R)	38 mm	30 mm	30 mm
Sagittal angle proximal holes A, B, C (A)	10° caudally	11° caudally	10° caudally

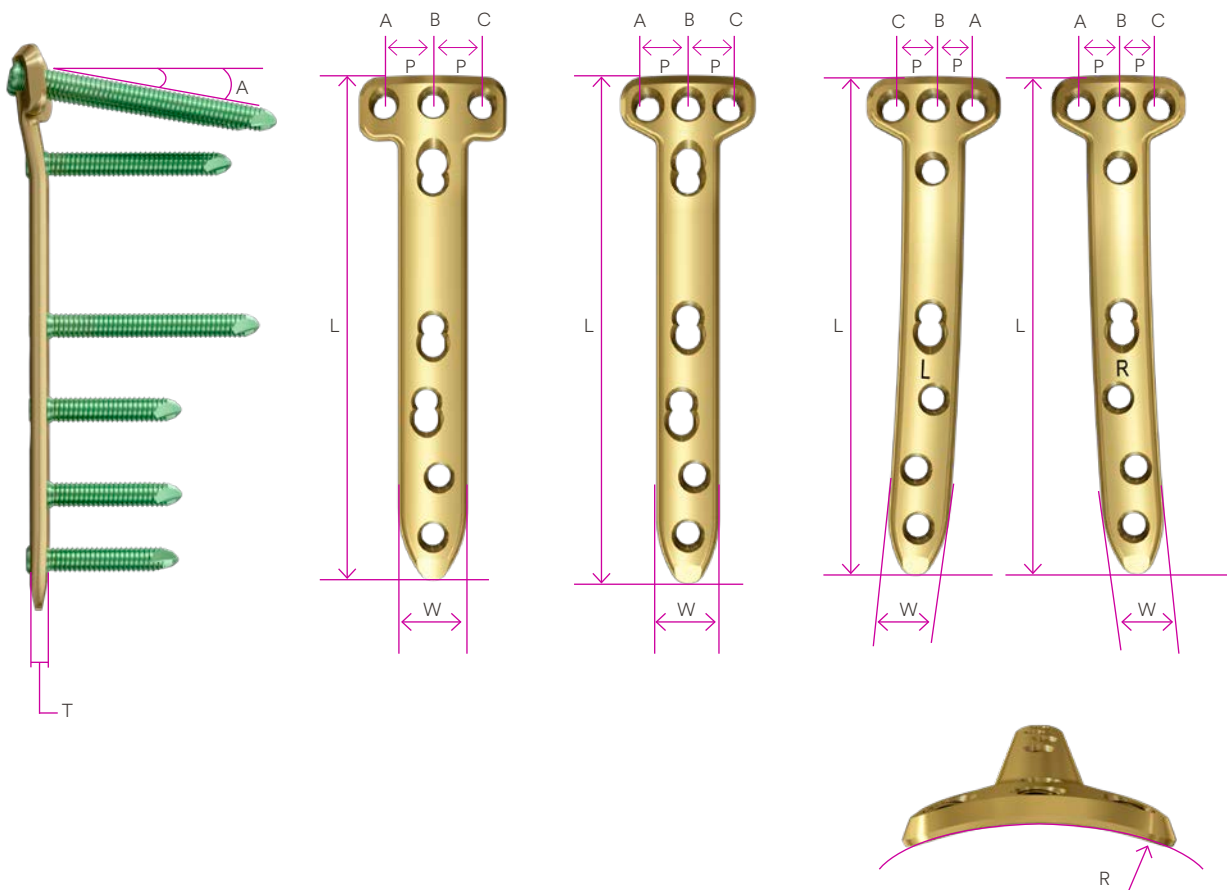

# Screws

---

413.309 LCP Spacer  $\varnothing$  5.0 mm, length 2 mm,  
Titanium Alloy (TAN)



---

413.324 – Locking Screws  $\varnothing$  5.0 mm, self-tapping,  
413.385 length 24 mm up to 85 mm,  
Titanium Alloy (TAN)



---

414.824 – Cortex Screws  $\varnothing$  4.5 mm, self-tapping,  
414.852 length 24 mm up to 52 mm,  
Pure Titanium



# Kirschner wires

---

310.243 Guide Wire Ø 2.5 mm with drill tip,  
length 200 mm, Stainless Steel



---

02.111.903 Kirschner Wire Ø 2.0 mm with drill tip,  
length 150 mm, Stainless Steel



---

292.210 Kirschner Wire Ø 2.0 mm with trocar tip,  
length 280 mm, Stainless Steel













## Alternative Kirschner wire

---

292.260 Kirschner Wire Ø 2.5 mm with trocar tip,  
length 280 mm, Stainless Steel



# Instruments

03.108.030	Alignment Rod	
03.108.031	Stand, large, for Alignment Rod, with handles	
03.108.032	Stand, small, for Alignment Rod	
03.401.083	Ruler, L 250 mm, Stainless Steel	
310.290	Drill Bit Ø 3.2 mm, length 195/170 mm, 2-flute, for Quick Coupling	
310.430	LCP Drill Bit Ø 4.3 mm with Stop, length 221 mm, 2-flute, for Quick Coupling	
312.924	Guiding Block for TomoFix Tibial Head Plate, small, medial, proximal	
312.926	TomoFix Guiding Block for TomoFix Tibial Head Plate, medial, proximal	
312.928	TomoFix Guiding Block for left TomoFix Tibial Head Plate, anatomical, proximal, medial, left	
312.929	TomoFix Guiding Block for right TomoFix Tibial Head Plate, anatomical, proximal, medial, right	

314.150 Screwdriver Shaft, hexagonal, large, Ø 3.5 mm



314.270 Screwdriver, hexagonal, large, Ø 3.5 mm, with Groove, length 245 mm



319.100 Depth Gauge for Screws Ø 4.5 to 6.5 mm, measuring range up to 110 mm



323.042 LCP Drill Sleeve 5.0, for Drill Bits Ø 4.3 mm



323.044 Centering Sleeve for Kirschner Wire Ø 2.0 mm, length 110 mm, for No. 323.042



323.500 LCP Universal Drill Guide 4.5/5.0



324.052 Torque-limiting Screwdriver 3.5, self-holding, for Locking Screws Ø 5.0 mm



395.001 TomoFix Osteotomy Gap Measuring Device, Stainless Steel



395.166 TomoFix Retractor





397.992	TomoFix Osteotomy Chisel, width 10 mm	
397.993	TomoFix Osteotomy Chisel, width 15 mm	
397.994	TomoFix Osteotomy Chisel, width 20 mm	
397.995	TomoFix Osteotomy Chisel, width 25 mm	
399.100	Bone Spreader, speed lock, width 8 mm, length 210 mm	
519.105	Saw Blade 70/49×20×0.6/0.4 mm, for Oscillating Saw with AO/ASIF Coupling	
519.108	Saw Blade 116/95×25×0.9/0.8 mm, for Oscillating Saw with AO/ASIF Coupling	

# Optional Instruments

323.040	Depth Gauge with Stop for Screws Ø 5.0 mm, measuring range to 110 mm, for No. 323.042	
324.060	Calliper for Corpectomy, short, Stainless Steel	
395.161	TomoFix Aiming Arm	
395.162	TomoFix Kirschner Wire Guide with Wing Nut	
395.163	TomoFix Saw Guide, left	
395.164	TomoFix Saw Guide, right	
395.165	TomoFix Angel Wing	
519.107	Saw Blade 116/95×19×0.9/0.8 mm, for Oscillating Saw with AO/ASIF Coupling, sterile	
519.118	Saw Blade 111/90×12.5×0.9/0.8 mm, for Oscillating Saw with AO/ASIF Coupling, sterile	

# Cases

---

68.109.020 Case for TomoFix Osteotomy  
Instruments, NTOC System

---

68.109.030 Screw Rack for TomoFix Screw Set  
4.5/5.0, NTOC System

---

68.109.040 Case for TomoFix LCP Instruments,  
NTOC System

# Optional Case

---

68.109.050 Case for TomoFix MHT Optional  
Instruments, compatible with  
68.109.040, NTOC System

# MRI Information

---

## **Torque, Displacement and Image Artifacts according to ASTM F 2213, ASTM F 2052 and ASTM F 2119**

Non-clinical testing of worst case scenario in a 3 T MRI system did not reveal any relevant torque or displacement of the construct for an experimentally measured local spatial gradient of the magnetic field of 3.69 T/m. The largest image artifact extended approximately 169 mm from the construct when scanned using the Gradient Echo (GE). Testing was conducted on a 3 T MRI system.

## **Radio-Frequency-(RF-)induced heating according to ASTM F 2182**

Non-clinical electromagnetic and thermal testing of worst case scenario lead to peak temperature rise of 9.5 °C with an average temperature rise of 6.6 °C (1.5 T) and a peak temperature rise of 5.9 °C (3 T) under MRI Conditions using RF Coils (whole body averaged specific absorption rate [SAR] of 2 W/kg for 6 minutes [1.5 T] and for 15 minutes [3 T]).

### **▲ Precautions:**

The above mentioned test relies on non-clinical testing. The actual temperature rise in the patient will depend on a variety of factors beyond the SAR and time of RF application. Thus, it is recommended to pay particular attention to the following points:

- It is recommended to thoroughly monitor patients undergoing MR scanning for perceived temperature and/or pain sensations.
- Patients with impaired thermoregulation or temperature sensation should be excluded from MR scanning procedures.
- Generally, it is recommended to use a MR system with low field strength in the presence of conductive implants. The employed specific absorption rate (SAR) should be reduced as far as possible.
- Using the ventilation system may further contribute to reduce temperature increase in the body.





Not all products are currently available in all markets.  
This publication is not intended for distribution in the USA.  
Intended use, Indications and Contraindications can be found in the corresponding system Instructions for Use.  
All Surgical Techniques are available as PDF files at [www.depuysynthes.com/ifu](http://www.depuysynthes.com/ifu)



Synthes GmbH  
Eimattstrasse 3  
4436 Oberdorf  
Switzerland  
Tel: +41 61 965 61 11

[www.depuysynthes.com](http://www.depuysynthes.com)